

PCI Bus

8-Axis Motor Control Board

# **MC8082P** Hardware Manual

2009-09-08 Ver. 1.0

2010-07-28 Ver. 1.1

2010-08-03 Ver. 1.2

2012-01-25 Ver. 1.3

**NOVA electronics**

## Prevent Electrostatic Discharge



**ATTENTION:** MC8082P is sensitive to electrostatic discharge, which can cause internal damage and affect normal operation. Follow these guidelines when you handle MC8082P:

- Touch a grounded object to discharge potential static.
- Wear an approved grounding wrist strap.
- Hold both ends of the board between your fingers or hold a mounting bracket.
- Do not touch connectors or pins on component boards.
- Do not touch circuit components on MC8082P.
- Store MC8082P in appropriate static-safe packaging when not in use.

## Safety Notice



**WARNING:** MC8082P is not designed or intended to be fail-safe, or for use in any application requiring fail-safe performance, such as in life-support or safety devices or systems that could lead to death, personal injury or severe property or environmental damage (individually and collectively, "critical applications"). Customer must be fully responsible for the use of MC8082P in critical applications. Provide adequate design and operating safeguards in order to minimize risks associated with customer's applications when incorporating MC8082P in a system.

## Before you begin



**ATTENTION:** Before using MC8082P, read this manual thoroughly to ensure correct usage and observe all the instructions given in this manual.

## Checking the Contents



**ATTENTION:** When you unpack a package of MC8082P, check for the following accessories. If something is missing or broken, contact the place of purchase.

- |                       |       |
|-----------------------|-------|
| ● MC8082P             | 1     |
| ● I/O Cable (CN2)     | 1     |
| ● 50P Connector (CN3) | 1 set |
| ● 30P Connector (CN4) | 1 set |

The user's manual and software are not with the package for resource-saving. If you need additional manuals or software, contact the place of purchase or contact us to the following email address as "novaelec\_info@novaelec.co.jp".

## Consulting Other Manuals



**ATTENTION:** The circuit of MC8082P consists of mainly two of 4-axis motion control IC "MCX304", a PCI-bus interface circuit and I/O interface circuits of each axis. Basic functions of this board all depend on MCX304, so please refer to the user's manual of MCX304 regarding these functions. This manual describes about Electric Specification of each axis I/O signal. Regarding the installation on Windows, API function for board control and sample program files for this board, see "MC8000P Device Driver Manual."

## Environmental Conditions



**ATTENTION:** Use the following environmental conditions.

Operating Temperature	0~45°C(32~113°F)
Humidity	20~90% (no condensation)
Floating dust	Not to be excessive
Corrosive gases	None
Electric supply source	DC+5V (±5%), external source: DC+24V

## Inspection and Maintenance



**ATTENTION:** Perform inspection and maintenance periodically for correct use.

Cable connection	The connector of the board and a cable should properly be connected.
Card-edge	No dust and no corrosion.
Connector terminal area	No dust and no corrosion.
On the IC and board	No excessive dust and no foreign substance.

## Handling Precautions



**ATTENTION:**

- Do not use in any location subject to shock, vibration, magnetism and electricity. Otherwise, the equipment may be damaged or malfunctioned.
- Do not disassemble, repair or modify the equipment.
- Do not connect or disconnect the board or cables while power is applied. Otherwise, breakdown or operation error may result.

- Information in this manual is subject to change without notice.
- Windows are registered trademark of Microsoft Corporation.

<b>1. Outline .....</b>	<b>1</b>
1.1 MCX304 Functional Restriction .....	2
1.2 PCI Bus Interface .....	2
1.3 Each Axis I/O Interface .....	2
<b>2. I/O Address Setting and Register .....</b>	<b>3</b>
<b>3. I/O Signals .....</b>	<b>4</b>
3.1 CN2 Connector (Rear connector) .....	4
3.2 CN3, 4 Connector (Connector on the board) .....	7
3.3 Drive Pulse Output Signal (nP+P, nP+N, nP-P, nP-N) .....	9
3.4 General Output Signal and Deviation Counter Clear Output Signal (nOUT3, nOUT2, nOUT1, nOUT0/DCC) .....	9
3.5 Over Run Limit Input Signal (nLMT+, nLMT-) .....	11
3.6 Decelerating Stop / Instant Stop (nSTOP0, nSTOP1) .....	13
3.7 Encoder Z-phase Input Signal (nSTOP2) .....	14
3.8 Input Signals for Servo Motor (nINPOS, nALARM) .....	15
3.9 Encoder A/B phase Input Signal (nECAP, nECAN, nECBP, nECBN) .....	16
3.10 Driving by External Signal (nEXOP+, nEXOP-) .....	17
3.11 Emergency Stop Input Signal (EMG) .....	17
3.12 External Power (VEX) .....	18
<b>4. Interrupt .....</b>	<b>19</b>
<b>5. Connection Example for Motor Driver .....</b>	<b>20</b>
5.1 Connection Example for Stepper Motor .....	20
5.2 Connection Example for AC servo motor driver .....	21
<b>6. Input/Output Signals Timing .....</b>	<b>22</b>
6.1 Reset .....	22
6.2 Beginning of Driving .....	22
6.3 Input Pulse Timing .....	22
6.4 Instant Stop Timing .....	23
6.5 Decelerating Stop Timing .....	23
<b>7. Board Dimensions .....</b>	<b>25</b>
<b>8. Specifications .....</b>	<b>26</b>

## Update history

Jan.25.2012 Ver. 1.3

Introduction All the introduction has been changed.

Aug.3.2010 Ver. 1.2

P.3

L2: Read/Write register ····→ Read/Write registers ····

P.20

L16: of MCX304 WR5 → of WR5

Jul. 28 2010 Ver. 1.1

P.i

L16: ■MCX304 Manual → ■Consulting Other Manuals

P.1

L2 : axes → axis

MC8082P Circuit Block Diagram

- The model of Line Driver 26C31 → AM26C31
- The arrow line which transmits clock signal from Crystal Oscillator toPIX132 is added.
- The title of figure "MC8082P Circuit Block Diagram" is added.

P.2

L4: ■OUT1 → ■MCX304-OUT1

L6: ■OUT2,3 → ■MCX304-OUT2,3

P.3

L2: Two of MCX304 (-A, B) of Read/Write register in the board  
→ Read/Write register of MCX304(-A,B) on the board  
MC8082P → MC8000P

L4: AU axes → AU axis

BU axes → BU axis

For details → For more details

P.4

L7 of "Signal type" in the table: axes → axis

P.6

L1 in Note: connecting → connecting or disconnecting

L2 in Note: connect → connect or disconnect

P.10

- The title of (1): Read output data currently set. → Read current output data.
- (2): turn ON with the current reading data. → turn ON.
- (3): turn OFF with the current reading data. → turn OFF.

P.11

L45: Input signal to restrain → It is the input signal to stop

L47: For details → For more details

L49: powered on by default, → powered on,

L50: 512  $\mu$  sec. → 512  $\mu$  sec as default.

P.13

L13: More details → For more details

L23: powered on by default, → powered on,

L24: 512  $\mu$  sec. → 512  $\mu$  sec as default.

P.14

L5: powered on by default, → powered on,

L6: 512  $\mu$  sec. → 512  $\mu$  sec as default.

L13: For details → For more details

P14

L15: line-drive → line-driver

L15: LOWER side → UPPER side

L15: line-drive → line-driver

L22: powered on by default, → powered on,  
512  $\mu$  sec. → 512  $\mu$  sec as default.  
from active to inactive. → from inactive to active.

L32: (to state reset) → (state of reset)

P.15

L2: (to state reset) → (state of reset)

L13: register 2 → register 2 (nRR2)

L23: powered on by default, → powered on,

L24: 512  $\mu$  sec. → 512  $\mu$  sec as default.

P.17

L4: For details, → For more details,

L9: powered on by default, → powered on,

L10: 512  $\mu$  sec. → 512  $\mu$  sec as default.

L22: powered on by default, → powered on,

L23: 512  $\mu$  sec. → 512  $\mu$  sec as default.

P.19

L11: allow / prohibit → enable / disable

P.20

5.1 Title: Stepper Motor → Stepper Motor Driver

L4: 5-phase → the 5-phase

L4: driver KR535M. → driver of TECHNO DRIVE KR535M.

L8: D0 bit of WR4 → D0 bit of MCX304 WR4

D0 bit of MCX304 WR5 → D0 bit of WR5

XOUT → XOUT0

L16: D0 bit of WR4 → D0 bit of MCX304 WR4

XOUT → XOUT0

P.22

6.1 Figure: nOUT4~7 → nOUT1~3

P.27

L24: EMGN → EMG

L39: CN3:HIF3FC-50PA-2.54R → CN3:HIF3FC-50PA-2.54DS

L40: CN3:HIF3FC-30PA-2.54R → CN3:HIF3FC-30PA-2.54DS

# 1. Outline

MC8082P is a PCI-bus compliant circuit board equipped with two of 4-axis motion control IC “MCX304”. It can independently control 8 axis of either stepper motor or pulse type servo drives for position and speed controls.

MC8082P functional block diagram is shown as follows. MC8082P consists of mainly two of 4-axis motion control IC “MCX304”, a PCI-bus interface circuit and I/O interface circuits of each axis: AX, AY, AZ, AU, BX, BY, BZ and BU. Therefore, basic functions of this board all depend on MCX304, so please refer to the user’s manual of MCX304 regarding these functions.

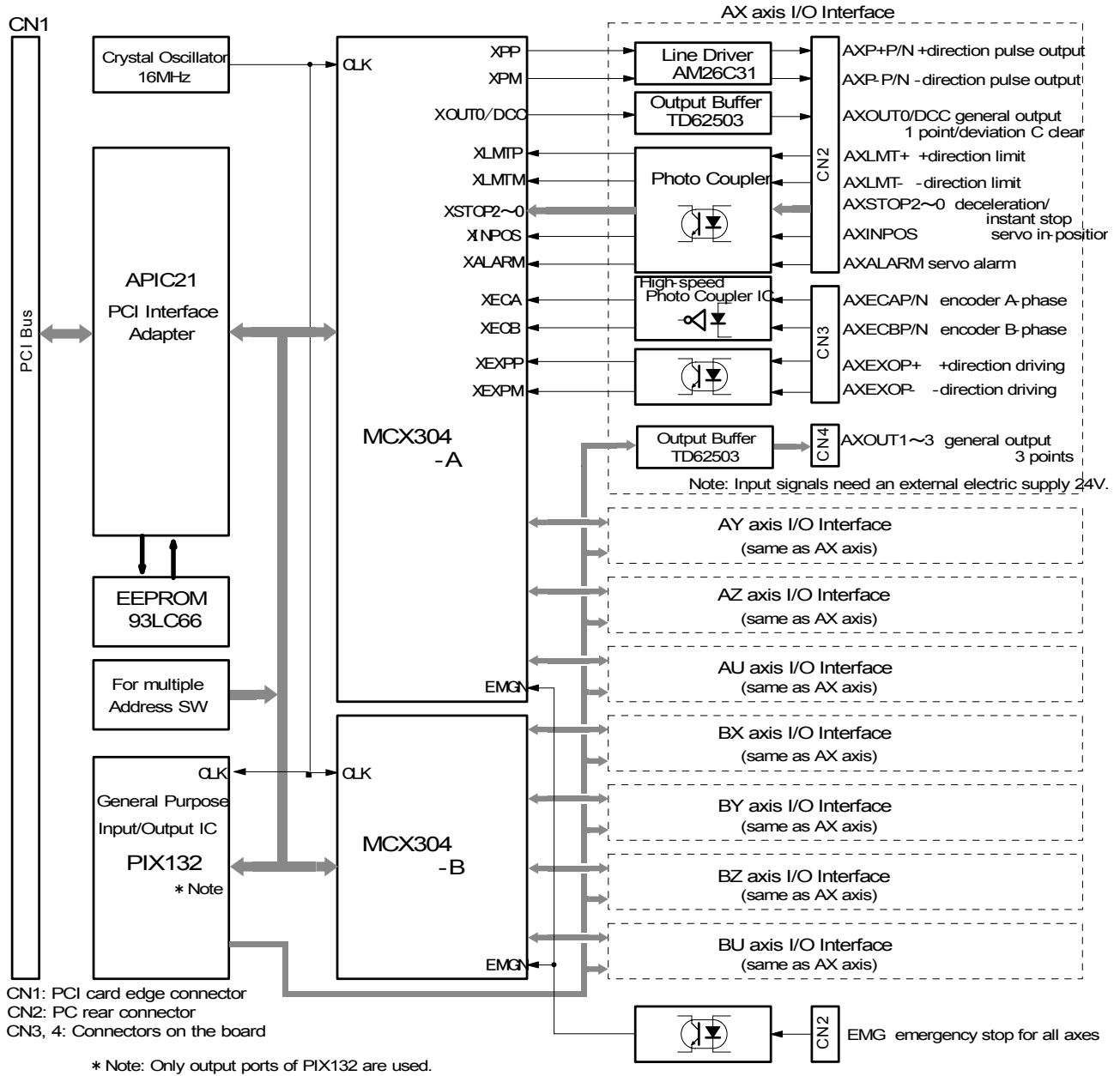

MC8082P Circuit Block Diagram

## 1.1 MCX304 Functional Restriction

MC8082P does not support the following MCX304 general output signals. However, it is equipped with PIX132(NOVA Electronics) on the board, so that each axis has four general output signals (MCX304-OUT0, PIX132-OUT1, 2, 3).

### ■ MCX304-OUT1 output signal

nSTOP2/OUT1 pin of MCX304 is used as STOP2 input, so it cannot be used as OUT1 output.

### ■ MCX304-OUT2, 3 output signals

D15~D8 are used due to 16-bit data bus performance. Therefore, OUT2, 3 signals cannot be used.

## 1.2 PCI Bus Interface

### ■ Occupied I/O Address

The board requires 24 I/O address locations for PCI bus. I/O addressing is determined by “plug and play” function of Windows.

### ■ Data Length

Data length is 16-bit. Read/Write access cannot be performed per byte.

### ■ Interrupt Signal

When using an interrupt to PCI bus, the board uses IRQ determined by “plug and play” function of Windows.

## 1.3 Each Axis I/O Interface

### ■ Drive Pulse Output (nP+P/N, nP-P/N)

Drive pulses in the +/- direction for motor driving are output a 50% duty cycle of from 1PPS to 4MPPS.

Drive pulse output signals of each direction are the differential line-driver output of AM26C31 line driver or equivalent.

### ■ General Output (nOUT3~0)

Each axis has 4 general outputs. Output buffer uses TD62503 (Toshiba) and is the open collector output with sustaining voltage 35V. Only nOUT0 signal is placed in the rear connector CN2. nOUT0 signal can be used as a deviation counter clear signal (DCC) for a servomotor. nOUT1, 2, 3 signals are placed in the connector CN4 on the board.

### ■ Over Run Limit Input (nLMT+, nLMT-)

Input signal to disable output pulse for + and – direction respectively. Decelerating stop and instant stop for active can be selected in mode setting. These input signals are isolated by photo coupler from internal circuit. 24V power supply is needed.

### ■ Decelerating Stop/Instant Stop Input (nSTOP2~0)

In automatic home search, this input signal is to stop drive pulse in deceleration or immediately from outside. Enable/Disable and active logical level can be selected in mode setting and each axis has three inputs. For encoder Z-phase signal, input to nSTOP2. The user can connect to the driver whose type of output circuit is open collector or differential line-driver. These input signals are isolated by photo coupler from internal circuit.

### ■ Servo Motor Input (nINPOS, nALARM)

INPOS (in-position) signal and ALARM signal for servo motor drivers can be input, which can also be used as general input signals. These input signals are isolated by photo coupler from internal circuit.

### ■ Encoder Input (nECAP/N, nECBP/N)

This signal inputs A/B phase signal from an encoder, which is placed in the connector CN3 on the board. nECAP/N, nECBP/N signals are for an encoder A/B phase signal input and count up or down 32-bit real position counter inside MCX304. These input signals are isolated by photo coupler from internal circuit and can easily be connected to a differential output line-driver.

### ■ Driving by External Input(nEXOP+, nEXOP-)

This signal externally controls driving in the + or – direction, which is placed in the connector CN3 on the board. In fixed driving mode, the input signal triggers (the falling edge) to output specified drive pulse. In continuous driving mode, drive pulse is output continuously while the input signal is low. This function can reduce the load of the host CPU, so the user can perform jog feed of each axis speedy. These input signals are isolated by photo coupler from internal circuit.

### ■ Emergency Stop Input (EMG)

This signal is to perform the emergency stop for all axes. Active logical level can be set by selecting a jumper on the board. This input signal is isolated by photo coupler from internal circuit.



## 2. I/O Address Setting and Register

I/O port address of the board is automatically determined by the plug and play function (PnP function) of the PCI bus. Read/Write registers of MCX304 (-A, B) on the board and ports of PIX132 can be accessed by API function which MC8000P device driver provides. Each register and I/O port address are as shown in the table below. MCX304-A controls AX, AY, AZ and AU axis and MCX304-B controls BX, BY, BX and BU axis. For more details on each register, see chapter 4 of MCX304 user's manual.

I/O Address	IC	Write Register	Read Register
00	MCX304-A	WR0 command register	RR0 main status register
01		XWR1 X axis mode register 1	XRR1 X axis status register 1
		YWR1 Y axis mode register 1	YRR1 Y axis status register 1
		ZWR1 Z axis mode register 1	ZRR1 Z axis status register 1
		UWR1 U axis mode register 1	URR1 U axis status register 1
02		XWR2 X axis mode register 2	XRR2 X axis status register 2
		YWR2 Y axis mode register 2	YRR2 Y axis status register 2
		ZWR2 Z axis mode register 2	ZRR2 Z axis status register 2
	UWR2 U axis mode register 2	URR2 U axis status register 2	
03	XWR3 X axis mode register 3	XRR3 X axis status register 3	
	YWR3 Y axis mode register 3	YRR3 Y axis status register 3	
	ZWR3 Z axis mode register 3	ZRR3 Z axis status register 3	
	UWR3 U axis mode register 3	URR3 U axis status register 3	
04	WR4 output register 1	RR4 input register 1	
05	WR5 output register 2	RR5 input register 2	
06	WR6 write data register 1	RR6 read data register 1	
07	WR7 write data register 2	RR7 read data register 2	
08	MCX304-B	WR0 command register	RR0 main status register
09		XWR1 X axis mode register 1	XRR1 X axis status register 1
		YWR1 Y axis mode register 1	YRR1 Y axis status register 1
		ZWR1 Z axis mode register 1	ZRR1 Z axis status register 1
		UWR1 U axis mode register 1	URR1 U axis status register 1
0A		XWR2 X axis mode register 2	XRR2 X axis status register 2
		YWR2 Y axis mode register 2	YRR2 Y axis status register 2
		ZWR2 Z axis mode register 2	ZRR2 Z axis status register 2
	UWR2 U axis mode register 2	URR2 U axis status register 2	
0B	XWR3 X axis mode register 3	XRR3 X axis status register 3	
	YWR3 Y axis mode register 3	YRR3 Y axis status register 3	
	ZWR3 Z axis mode register 3	ZRR3 Z axis status register 3	
	UWR3 U axis mode register 3	URR3 U axis status register 3	
0C	WR4 output register 1	RR4 input register 1	
0D	WR5 output register 2	RR5 input register 2	
0E	WR6 write data register 1	RR6 read data register 1	
0F	WR7 write data register 2	RR7 read data register 2	
10	PIX132	write prohibit	invalid
11		write prohibit	invalid
12		write prohibit	invalid
13		write prohibit	invalid
14		Port A output data (Set to D7~D0)	Port A output data reading (D7~D0)
15		Port B output data (Set to D7~D0)	Port B output data reading (D7~D0)
16		Port C output data (Set to D7~D0)	Port C output data reading (D7~D0)
17		invalid	invalid

### 3. I/O Signals

This chapter describes each I/O signals of the I/O connector. In the description, the signal name of each axis is described as n○○○○. This “n” means AX, AY, AZ, AU, BX, BY, BZ and BU.

#### 3.1 CN2 Connector (Rear connector)

CN2 connector is equipped with external power (+24VDC) input, and inputs/outputs signals of each axis as shown below.

Connector	Signal Type	Signal Name
CN2	Drive pulse output signal in the +/- direction	nP+P/N, nP-P/N
	Over run limit input signal in the +/- direction	nLMT+, nLMT-
	Decelerating stop/Instant stop input signal 3 points	nSTOP0, nSTOP1, nSTOP2
	In-position and alarm input signal for servo motor	nINPOS, nALARM
	Deviation counter clear output signal for servo motor (shared with general output 1 point)	nOUT0/DCC
Emergency stop input signal for all axis	EMG	

CN2 Connector Pin Assignments

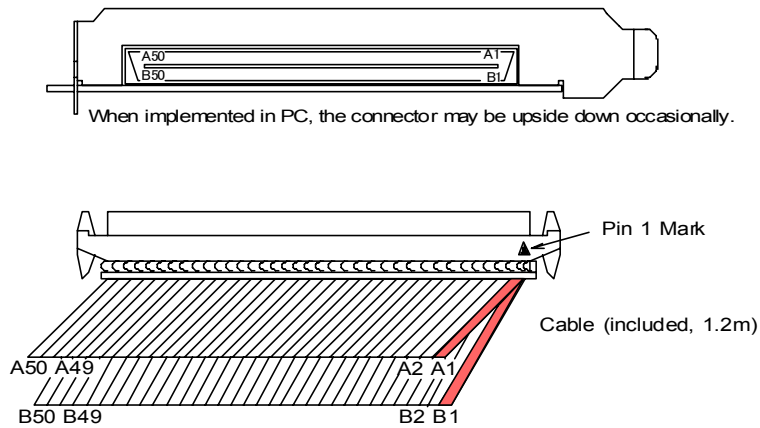

The cable (included) is A1, A2, ... A49, A50 from the right (red) of the upper cable to the left, and B1, B2, ... B49, B50 from the right (red) of the lower cable to the left when Pin 1 mark (▲) of the connector is placed in the upper right.

Connector type: Board side FX2B-100PA-1.27DS (Hirose), Cable side FX2B-100SA-1.27R (Hirose)

## CN2 Connector

Pin	Signal	I/O	Content	Chapter
A1	VEX		External Power (+24V)	3.12
A2	AXLMT+	Input	AX axis Limit in + direction	3.5
A3	AXLMT-	Input	AX axis Limit in – direction	3.5
A4	AXSTOP0	Input	AX axis Decelerating Stop / Instant Stop	3.6
A5	AXSTOP1	Input	AX axis Decelerating Stop / Instant Stop	3.6
A6	AYLMT+	Input	AY axis Limit in + direction	3.5
A7	AYLMT-	Input	AY axis Limit in – direction	3.5
A8	AYSTOP0	Input	AY axis Decelerating Stop / Instant Stop	3.6
A9	AYSTOP1	Input	AY axis Decelerating Stop / Instant Stop	3.6
A10	AZLMT+	Input	AZ axis Limit in + direction	3.5
A11	AZLMT-	Input	AZ axis Limit in – direction	3.5
A12	AZSTOP0	Input	AZ axis Decelerating Stop / Instant Stop	3.6
A13	AZSTOP1	Input	AZ axis Decelerating Stop / Instant Stop	3.6
A14	AULMT+	Input	AU axis Limit in + direction	3.5
A15	AULMT-	Input	AU axis Limit in – direction	3.5
A16	AUSTOP0	Input	AU axis Decelerating Stop / Instant Stop	3.6
A17	AUSTOP1	Input	AU axis Decelerating Stop / Instant Stop	3.6
A18	AXSTOP2	Input	AX axis Encoder Z-phase	3.7
A19	AXINPOS	Input	AX axis Inposition	3.8
A20	AXALARM	Input	AX axis Alarm	3.8
A21	AYSTOP2	Input	AY axis Encoder Z-phase	3.7
A22	AYINPOS	Input	AY axis Inposition	3.8
A23	AYALARM	Input	AY axis Alarm	3.8
A24	AZSTOP2	Input	AZ axis Encoder Z-phase	3.7
A25	AZINPOS	Input	AZ axis Inposition	3.8
A26	AZALARM	Input	AZ axis Alarm	3.8
A27	AUSTOP2	Input	AU axis Encoder Z-phase	3.7
A28	AUINPOS	Input	AU axis Inposition	3.8
A29	AUALARM	Input	AU axis Alarm	3.8
A30	GND		Internal Circuit GND	
A31	AXOUT0/DCC	Output	AX axis General Output/DCC Note1	3.4
A32	AYOUT0/DCC	Output	AY axis General Output/DCC	3.4
A33	AZOUT0/DCC	Output	AZ axis General Output/DCC	3.4
A34	AUOUT0/DCC	Output	AU axis General Output/DCC	3.4
A35	AXP+P	Output	AX axis Drive Pulse in + direction	3.3
A36	AXP+N	Output	AX axis Drive Pulse in + direction	3.3
A37	AXP-P	Output	AX axis Drive Pulse in – direction	3.3
A38	AXP-N	Output	AX axis Drive Pulse in – direction	3.3
A39	AYP+P	Output	AY axis Drive Pulse in + direction	3.3
A40	AYP+N	Output	AY axis Drive Pulse in + direction	3.3
A41	AYP-P	Output	AY axis Drive Pulse in – direction	3.3
A42	AYP-N	Output	AY axis Drive Pulse in – direction	3.3
A43	AZP+P	Output	AZ axis Drive Pulse in + direction	3.3
A44	AZP+N	Output	AZ axis Drive Pulse in + direction	3.3
A45	AZP-P	Output	AZ axis Drive Pulse in – direction	3.3
A46	AZP-N	Output	AZ axis Drive Pulse in – direction	3.3
A47	AUP+P	Output	AU axis Drive Pulse in + direction	3.3
A48	AUP+N	Output	AU axis Drive Pulse in + direction	3.3
A49	AUP-P	Output	AU axis Drive Pulse in – direction	3.3
A50	AUP-N	Output	AU axis Drive Pulse in – direction	3.3

Note1: DCC (Deviation Counter Clear): Output to clear the deviation counter of a servo motor driver.

## CN2 Connector

Pin	Signal	I/O	Content	Chapter
B1	EMG	Input	Emergency Stop (All axes)	3.11
B2	BXLMT+	Input	BX axis Limit in + direction	3.5
B3	BXLMT-	Input	BX axis Limit in – direction	3.5
B4	BXSTOP0	Input	BX axis Decelerating Stop / Instant Stop	3.6
B5	BXSTOP1	Input	BX axis Decelerating Stop / Instant Stop	3.6
B6	BYLMT+	Input	BY axis Limit in + direction	3.5
B7	BYLMT-	Input	BY axis Limit in – direction	3.5
B8	BYSTOP0	Input	BY axis Decelerating Stop / Instant Stop	3.6
B9	BYSTOP1	Input	BY axis Decelerating Stop / Instant Stop	3.6
B10	BZLMT+	Input	BZ axis Limit in + direction	3.5
B11	BZLMT-	Input	BZ axis Limit in – direction	3.5
B12	BZSTOP0	Input	BZ axis Decelerating Stop / Instant Stop	3.6
B13	BZSTOP1	Input	BZ axis Decelerating Stop / Instant Stop	3.6
B14	BULMT+	Input	BU axis Limit in + direction	3.5
B15	BULMT-	Input	BU axis Limit in – direction	3.5
B16	BUSTOP0	Input	BU axis Decelerating Stop / Instant Stop	3.6
B17	BUSTOP1	Input	BU axis Decelerating Stop / Instant Stop	3.6
B18	BXSTOP2	Input	BX axis Encoder Z-phase	3.7
B19	BXINPOS	Input	BX axis Inposition	3.8
B20	BXALARM	Input	BX axis Alarm	3.8
B21	BYSTOP2	Input	BY axis Encoder Z-phase	3.7
B22	BYINPOS	Input	BY axis Inposition	3.8
B23	BYALARM	Input	BY axis Alarm	3.8
B24	BZSTOP2	Input	BZ axis Encoder Z-phase	3.7
B25	BZINPOS	Input	BZ axis Inposition	3.8
B26	BZALARM	Input	BZ axis Alarm	3.8
B27	BUSTOP2	Input	BU axis Encoder Z-phase	3.7
B28	BUINPOS	Input	BU axis Inposition	3.8
B29	BUALARM	Input	BU axis Alarm	3.8
B30	GND		Internal Circuit GND	
B31	BXOUT0/DCC	Output	BX axis General Output/DCC Note1	3.4
B32	BYOUT0/DCC	Output	BY axis General Output/DCC	3.4
B33	BZOUT0/DCC	Output	BZ axis General Output/DCC	3.4
B34	BUOUT0/DCC	Output	BU axis General Output/DCC	3.4
B35	BXP+P	Output	BX axis Drive Pulse in + direction	3.3
B36	BXP+N	Output	BX axis Drive Pulse in + direction	3.3
B37	BXP-P	Output	BX axis Drive Pulse in – direction	3.3
B38	BXP-N	Output	BX axis Drive Pulse in – direction	3.3
B39	BYP+P	Output	BY axis Drive Pulse in + direction	3.3
B40	BYP+N	Output	BY axis Drive Pulse in + direction	3.3
B41	BYP-P	Output	BY axis Drive Pulse in – direction	3.3
B42	BYP-N	Output	BY axis Drive Pulse in – direction	3.3
B43	BZP+P	Output	BZ axis Drive Pulse in + direction	3.3
B44	BZP+N	Output	BZ axis Drive Pulse in + direction	3.3
B45	BZP-P	Output	BZ axis Drive Pulse in – direction	3.3
B46	BZP-N	Output	BZ axis Drive Pulse in – direction	3.3
B47	BUP+P	Output	BU axis Drive Pulse in + direction	3.3
B48	BUP+N	Output	BU axis Drive Pulse in + direction	3.3
B49	BUP-P	Output	BU axis Drive Pulse in – direction	3.3
B50	BUP-N	Output	BU axis Drive Pulse in – direction	3.3

Note1: DCC (Deviation Counter Clear): Output to clear the deviation counter of a servo motor driver.

Note: When connecting or disconnecting the cable into the CN2 connector, turn OFF PC first and turn OFF external power (DC+24V), then connect or disconnect the cable. Otherwise, the destruction of the internal circuit may be caused. Be careful about the connector direction and not to reverse it.

### 3.2 CN3, 4 Connector (Connector on the board)

CN3, 4 connectors on the board input/output signals of each axis as shown below.

Connector	Signal Type	Signal Name
CN3	Driving by external input signal in the +/- direction (can be used as general input) Encoder A/B phase input signal	nEXOP+, nEXOP- nECAP/N, nECBP/N
CN4	General output signal (3 points/axis)	nOUT1, 2, 3

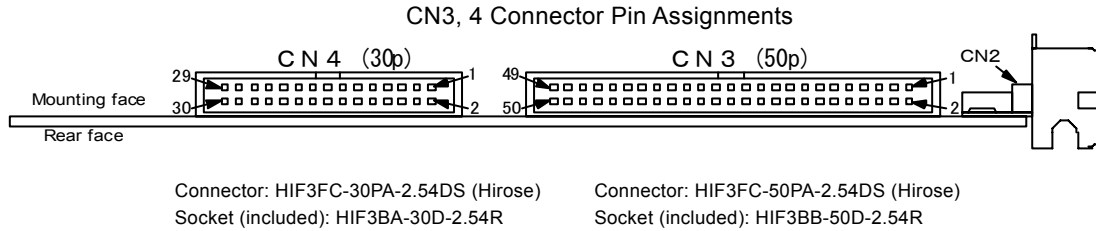

#### CN3 Connector

Pin	Signal	I/O	Content	Chapter	Pin	Signal	I/O	Content	Chapter
1	VEX		External Power (+24V)	3.12	2	VEX		External Power (+24V)	3.12
3	AXEXOP+	Input	AX axis Driving by External Signal in + direction	3.10	4	AXEXOP-	Input	AX axis Driving by External Signal in - direction	3.10
5	AYEXOP+	Input	AY axis Driving by External Signal in + direction	3.10	6	AYEXOP-	Input	AY axis Driving by External Signal in - direction	3.10
7	AZEXOP+	Input	AZ axis Driving by External Signal in + direction	3.10	8	AZEXOP-	Input	AZ axis Driving by External Signal in - direction	3.10
9	AUEXOP+	Input	AU axis Driving by External Signal in + direction	3.10	10	AUEXOP-	Input	AU axis Driving by External Signal in - direction	3.10
11	BXEXOP+	Input	BX axis Driving by External Signal in + direction	3.10	12	BXEXOP-	Input	BX axis Driving by External Signal in - direction	3.10
13	BYEXOP+	Input	BY axis Driving by External Signal in + direction	3.10	14	BYEXOP-	Input	BY axis Driving by External Signal in - direction	3.10
15	BZEXOP+	Input	BZ axis Driving by External Signal in + direction	3.10	16	BZEXOP-	Input	BZ axis Driving by External Signal in - direction	3.10
17	BUEXOP+	Input	BU axis Driving by External Signal in + direction	3.10	18	BUEXOP-	Input	BU axis Driving by External Signal in - direction	3.10
19	AXECAP	Input	AX axis Encoder A phase (+)	3.9	20	AXECAN	Input	AX axis Encoder A phase (-)	3.9
21	AXECBP	Input	AX axis Encoder B phase (+)	3.9	22	AXECBN	Input	AX axis Encoder B phase (-)	3.9
23	AYECAP	Input	AY axis Encoder A phase (+)	3.9	24	AYECAN	Input	AY axis Encoder A phase (-)	3.9
25	AYECBP	Input	AY axis Encoder B phase (+)	3.9	26	AYECBN	Input	AY axis Encoder B phase (-)	3.9
27	AZECAP	Input	AZ axis Encoder A phase (+)	3.9	28	AZECAN	Input	AZ axis Encoder A phase (-)	3.9
29	AZECBP	Input	AZ axis Encoder B phase (+)	3.9	30	AZECBN	Input	AZ axis Encoder B phase (-)	3.9
31	AUECAP	Input	AU axis Encoder A phase (+)	3.9	32	AUECAN	Input	AU axis Encoder A phase (-)	3.9
33	AUECBP	Input	AU axis Encoder B phase (+)	3.9	34	AUECBN	Input	AU axis Encoder B phase (-)	3.9
35	BXECAP	Input	BX axis Encoder A phase (+)	3.9	36	BXECAN	Input	BX axis Encoder A phase (-)	3.9
37	BXECBP	Input	BX axis Encoder B phase (+)	3.9	38	BXECBN	Input	BX axis Encoder B phase (-)	3.9
39	BYECAP	Input	BY axis Encoder A phase (+)	3.9	40	BYECAN	Input	BY axis Encoder A phase (-)	3.9
41	BYECBP	Input	BY axis Encoder B phase (+)	3.9	42	BYECBN	Input	BY axis Encoder B phase (-)	3.9
43	BZECAP	Input	BZ axis Encoder A phase (+)	3.9	44	BZECAN	Input	BZ axis Encoder A phase (-)	3.9
45	BZECBP	Input	BZ axis Encoder B phase (+)	3.9	46	BZECBN	Input	BZ axis Encoder B phase (-)	3.9
47	BUECAP	Input	BU axis Encoder A phase (+)	3.9	48	BUECAN	Input	BU axis Encoder A phase (-)	3.9
49	BUECBP	Input	BU axis Encoder B phase (+)	3.9	50	BUECBN	Input	BU axis Encoder B phase (-)	3.9

## CN4 Connector

Pin	Signal	I/O	Content	Chapter	Pin	Signal	I/O	Content	Chapter
1	VEX		External Power (+24V)	3.12	2	VEX		External Power (+24V)	3.12
3	AXOUT1/PA0	Output	AX axis General Output	3.4	4	AXOUT2/PA1	Output	AX axis General Output	3.4
5	AXOUT3/PA2	Output	AX axis General Output	3.4	6	AYOUT1/PA3	Output	AY axis General Output	3.4
7	AYOUT2/PA4	Output	AY axis General Output	3.4	8	AYOUT3/PA5	Output	AY axis General Output	3.4
9	AZOUT1/PA6	Output	AZ axis General Output	3.4	10	AZOUT2/PA7	Output	AZ axis General Output	3.4
11	AZOUT3/PB0	Output	AZ axis General Output	3.4	12	AUOUT1/PB1	Output	AU axis General Output	3.4
13	AUOUT2/PB2	Output	AU axis General Output	3.4	14	AUOUT3/PB3	Output	AU axis General Output	3.4
15	BXOUT1/PB4	Output	BX axis General Output	3.4	16	BXOUT2/PB5	Output	BX axis General Output	3.4
17	BXOUT3/PB6	Output	BX axis General Output	3.4	18	BYOUT1/PB7	Output	BY axis General Output	3.4
19	BYOUT2/PC0	Output	BY axis General Output	3.4	20	BYOUT3/PC1	Output	BY axis General Output	3.4
21	BZOUT1/PC2	Output	BZ axis General Output	3.4	22	BZOUT2/PC3	Output	BZ axis General Output	3.4
23	BZOUT3/PC4	Output	BZ axis General Output	3.4	24	BUOUT1/PC5	Output	BU axis General Output	3.4
25	BUOUT2/PC6	Output	BU axis General Output	3.4	26	BUOUT3/PC7	Output	BU axis General Output	3.4
27	GND		Internal Circuit GND		28	GND		Internal Circuit GND	
29	GND		Internal Circuit GND		30	GND		Internal Circuit GND	

### 3.3 Drive Pulse Output Signal (nP+P, nP+N, nP-P, nP-N)

Drive pulse output signal outputs the drive pulse of +/- direction of MCX304 through a differential line-driver output (AM26C31 or equivalent). nP+N is the reverse output of nP+P and nP-N is the reverse output of nP-P. At resetting, positive output (nP+P, nP-P) becomes low level and reverse output (nP+N, nP-N) becomes hi level. Drive pulse output is set to independent 2-pulse type after resetting; however, the user can change to 1-pulse 1-direction type in mode setting. See chapter 2.6.2 and 4.5 of MCX304 user's manual.

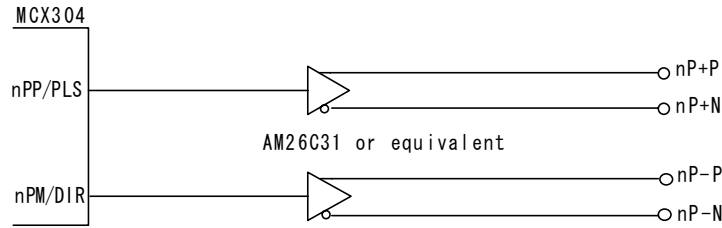

Drive Pulse Output Signal Circuit

The following is the connection example of a motor driver with a photo coupler input and line receiver input.

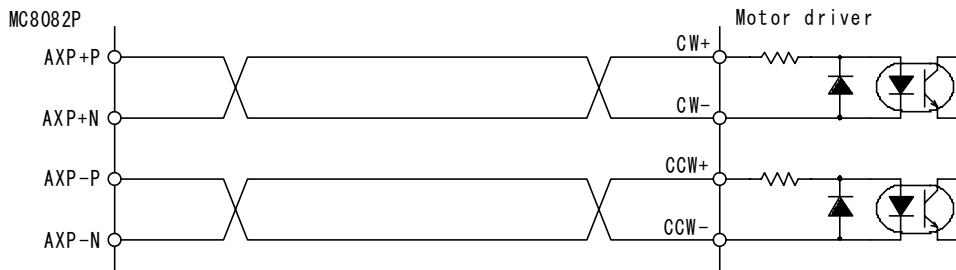

Connection example of a motor driver with a photo coupler input

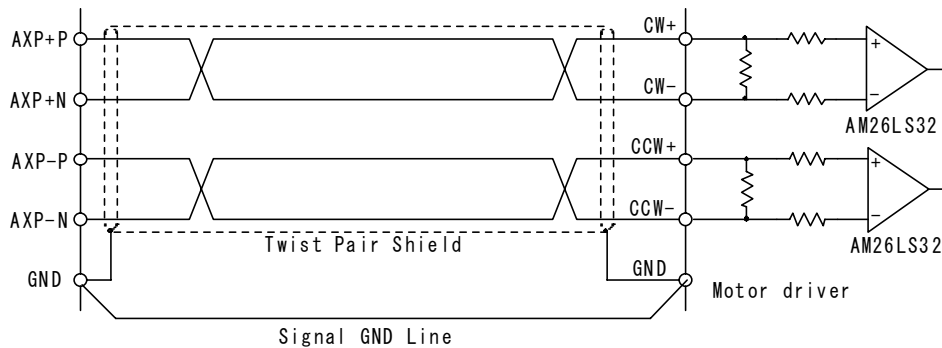

Connection example of a motor driver with a line receiver input

Note1: As shown above, when using a line receiver input circuit, connect MC8082P and a motor driver with GND line. If there is the potential difference between MC8082P and motor driver, the malfunction and destruction of a driver circuit and/or a motor driver circuit may be caused.

### 3.4 General Output Signal and Deviation Counter Clear Output Signal (nOUT3, nOUT2, nOUT1, nOUT0/DCC)

General output signal outputs a total of 4 points/axis, one nOUT0/DCC output signal in MCX304 and three output signals in PIX132, through buffer (TD62503). nOUT0 signal is shared with deviation counter clear output (DCC) and is output from CN2 connector. Also other general output signals: nOUT3, 2, 1 are output from CN4 connector. At resetting, all the output signals (open collector output) will be OFF.

■ nOUT3, 2, 1 Output

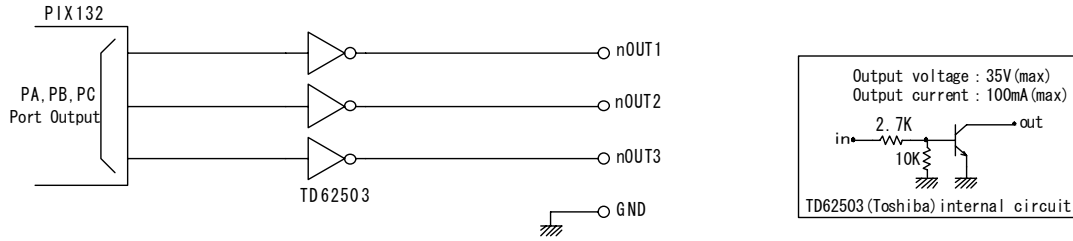

General Output Circuit

nOUT3~1 general output signals are output from CN4. ON/OFF of this signal can be controlled by writing to each port of PIX132 (NOVA electronics). Each port is set to output and becomes OFF when the PC system is started.

ON/OFF of nOUT3, 2, 1 output signals can be controlled by the following steps (1)~(4) on the program.

(1) Read current output data.

Check the the port number of the signal which the user wants to output, according to the table below.

Using Nmc\_InPort function, the user can read the current output of the port.

```
mcb0pa = Nmc_InPort(Board number, Port address);
```

→ 0x14, 0x15, 0x16  
 → 0x0~0xF

Example) Read the output data of the portA. `mcb0pa = Nmc_InPort(0x0, 0x14);`

(2) When turning ON the output.

Set 1 to the bit corresponding to the signal which the user wants to turn ON.

Example) Turn ON AXOUT1 output signal.

```
mcb0pa = mcb0pa | 0x01;     AXOUT1 is bit 0 of 0x14 port address from the table below.
```

(3) When turning OFF the output.

Set 0 to the bit corresponding to the signal which the user wants to turn OFF.

Example) Turn OFF AXOUT1 output signal.

```
mcb0pa = mcb0pa & 0xfe;
```

(4) Set the output data.

`Nmc_OutPort(Board number, Port address, Output data);`

Example) Write the output data to the port A `Nmc_OutPort(0x0, 0x14, mcb0pa);`

General Output Signal(CN4pin),Register Bit Table

CN4 Pin	Signal	Port Address	Bit	CN4 Pin	Signal	Port Address	Bit
3	AXOUT1/PA0	0x14	0	4	AXOUT2/PA1	0x14	1
5	AXOUT3/PA2	0x14	2	6	AYOUT1/PA3	0x14	3
7	AYOUT2/PA4	0x14	4	8	AYOUT3/PA5	0x14	5
9	AZOUT1/PA6	0x14	6	10	AZOUT2/PA7	0x14	7
11	AZOUT3/PB0	0x15	0	12	AUOUT1/PB1	0x15	1
13	AUOUT2/PB2	0x15	2	14	AUOUT3/PB3	0x15	3
15	BXOUT1/PB4	0x15	4	16	AXOUT2/PB5	0x15	5
17	BXOUT3/PB6	0x15	6	18	AYOUT1/PB7	0x15	7
19	BYOUT2/PC0	0x16	0	20	AYOUT3/PC1	0x16	1
21	BZOUT1/PC2	0x16	2	22	AZOUT2/PC3	0x16	3
23	BZOUT3/PC4	0x16	4	24	AUOUT1/PC5	0x16	5
25	BUOUT2/PC6	0x16	6	26	AUOUT3/PC7	0x16	7



General Output Signal, Register Bit Table

PortA (OX14)	Bit number	7	6	5	4	3	2	1	0
Output signal		PA7	PA6	PA5	PA4	PA3	PA2	PA1	PA0
		AZOUT2	AZOUT1	AYOUT3	AYOUT2	AYOUT1	AXOUT3	AXOUT2	AXOUT1

PortB (OX15)	Bit number	7	6	5	4	3	2	1	0
Output signal		PB7	PB6	PB5	PB4	PB3	PB2	PB1	PB0
		BYOUT1	BXOUT3	BXOUT2	BXOUT1	AUOUT3	AUOUT2	AUOUT1	AZOUT3

PortC (OX16)	Bit number	7	6	5	4	3	2	1	0
Output signal		PC7	PC6	PC5	PC4	PC3	PC2	PC1	PC0
		BUOUT3	BUOUT2	BUOUT1	BZOUT3	BZOUT2	BZOUT1	BYOUT3	BYOUT2

Examples of ON/OFF control of nOUT3, 2, 1 output signals are described in sample program, so refer to it.

### ■ nOUT0/DCC Output

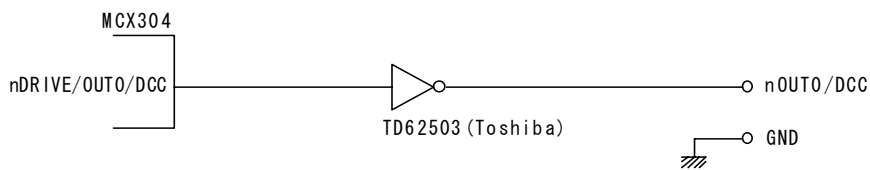

nOUT0/DCC output is shared with general output signal (nOUT0) and deviation counter clear output (DCC), and is output to CN2. At resetting, it will be OFF. Control of this signal is different from other general output, it can be performed by writing to the register of MCX304.

When used as general output.

- (1) To enable nOUT0 output, set the nOT0E bit of MCX304/WR5 to 1.
- (2) Turn ON: Set the nOUT0 bit of MCX304/WR4 to 1. Turn OFF: Set the nOUT0 bit of MCX304/WR4 to 0.

When used as deviation counter clear output.

Deviation counter clear output is the output to clear a deviation counter in a servo motor driver. MCX304 has the function to output this deviation counter clear signal during automatic home search.

For setting of a deviation counter clear enable, a logical level and pulse width, see chapter 2.4.3 of MCX304 user's manual. And for automatic home search details, see chapter 2.4. As shown in the figure above, TD62503 is used as buffer on the board, so that the board output (open collector) turns ON when MCX304 output is active Hi.

## 3.5 Over Run Limit Input Signal (nLMT+, nLMT-)

It is the input signal to stop each drive pulse in the +/ - direction. This input signal is connected to the limit input of MCX304 through a photo coupler. After resetting, MCX304 becomes low active, so limit function works when electric current flows from a signal pin (nLMT+, nLMT-). For more details on mode setting, see chapter 4.5 of MCX304 user's manual.

To enable this signal, external power supply DC24V is needed. When the board is powered on, a built-in filter of this signal becomes the setting of signal delay time 512  $\mu$  sec as default. This signal delay time can be changed for circumstances of system noise. For more details, see chapter 2.6.9 and 4.6 of MCX304 user's manual.

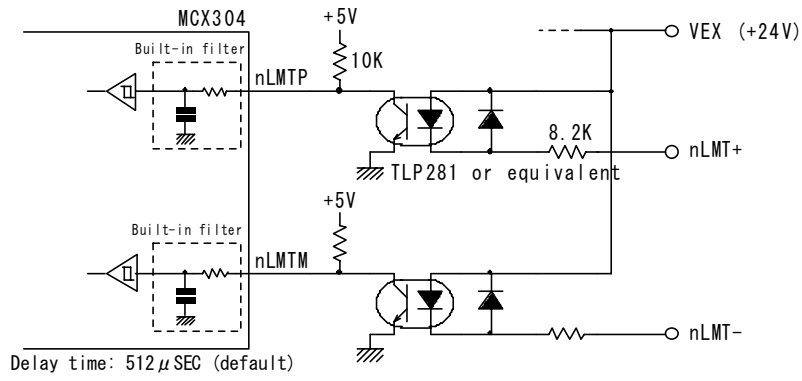

Over Run Limit Input Signal Circuit

The connection example of an over run limit input signal and a photo microsensor is shown below. When D3 bit of AX axis mode register 2 (XWR2) is set to 0 (the mode at reset), limit function becomes active at the light interception.

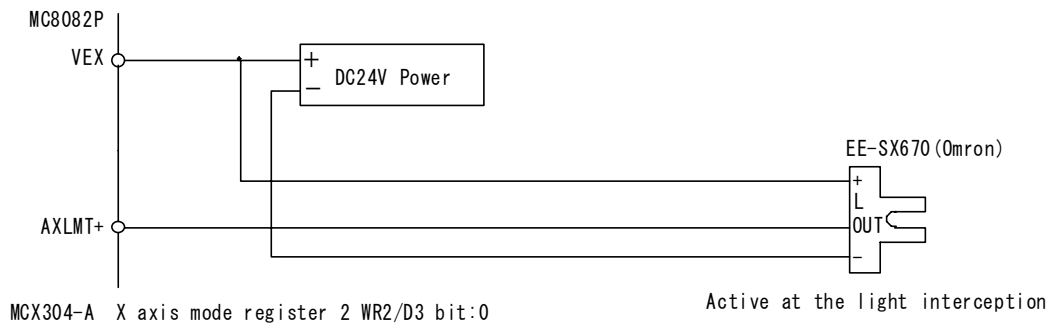

Connection Example of Over Run Limit Input Signal and Photo Microsensor

When long wiring is needed, use the shield cable.

### 3.6 Decelerating Stop / Instant Stop (nSTOP0, nSTOP1)

Input signal to stop drive pulse output in deceleration or immediately. Generally, nSTOP0 signal is used as a near home signal and nSTOP1 signal is used as a home signal. MCX304 has three signals, STOP2~STOP0 for each axis as a home search input signal; however, STOP2 is equipped with an interface circuit for encoder Z-phase. STOP1 signal is used as an input signal for home and STOP0 is for near home.

#### [Enable/Disable and Logical setting]

Each input signal can be set enable/disable and logical level in mode setting. When enable is set in mode setting, and when this signal becomes active during driving, drive pulse output stops. When during acceleration/deceleration driving, it stops in deceleration and when during constant driving, it stops immediately. After resetting, all the signals are disabled. For instant, when D1, D0 bit of A-XWR1 register is set to 1, 0 and set to low level and enable, and when current flows out from AXSTOP0 signal pin (CN2-A4) of this board, driving stops. For more details on mode setting, see chapter 4.4 of MCX304 user's manual.

#### [Automatic Home Search]

MCX304 has automatic home search function. See chapter 2.4 of MCX304 user's manual.

To perform high-speed home search → low-speed home search by only one signal, use nSTOP0 signal and switch JP3 jumper to UPPER side as follows:

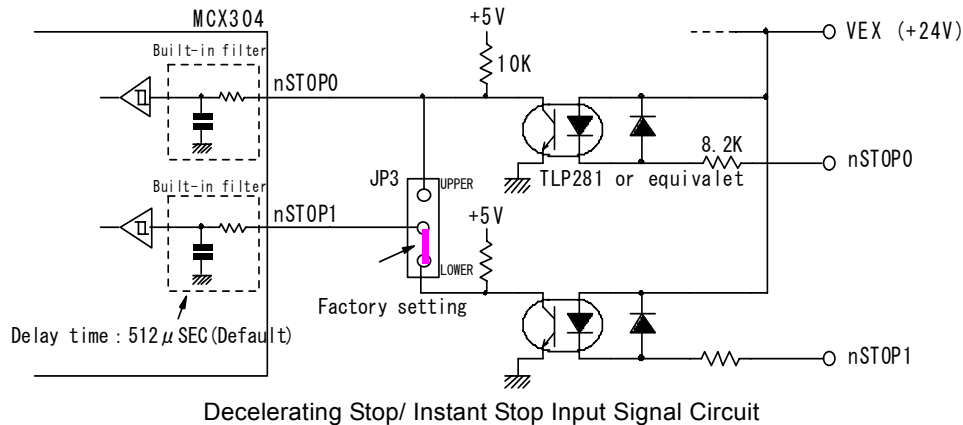

To enable this signal, external power supply DC24V is needed. When the board is powered on, a built-in filter in this signal becomes the setting of signal delay time 512  $\mu$  sec as default. This signal delay time can be changed for circumstances of system noise. For more details, see chapter 2.6.9 and 4.6 of MCX304 user's manual.

This signal can read out the signal status by input register 1, 2 (RR4, 5) at any time, so it can be used as general input.

### 3.7 Encoder Z-phase Input Signal (nSTOP2)

nSTOP2 input signal is to stop drive pulse output during driving by connecting to the Z-phase output signal of an encoder or a servo motor driver.

To enable this signal, external power supply DC24V is needed. When the board is powered on, a built-in filter in this signal becomes the setting of signal delay time  $512\ \mu\text{sec}$  as default. This signal delay time can be changed for circumstances of system noise. For more details, see chapter 2.6.9 and 4.6 of MCX304 user's manual.

#### [Enable/Disable and Logical setting]

nSTOP2 signal can be set enable/disable and logical level in mode setting as well as nSTOP1, 0 signal. For instant, when D5, D4 bit of WR1 register is set to 1, 0 and set to low and enable, and when current flows out from nSTOP2 signal pin of this board, driving stops. For more details on mode setting, see chapter 4.4 of MCX304 user's manual.

#### [Jumper setting]

This input signal can be adapted to either open collector output or line-driver output of the other output side by switching JP4 jumper. When the other side is open collector output, set JP4 to LOWER side (factory setting) and when is line-driver output, set JP4 to UPPER side and connect nSTOP2 signal to one side of line-driver output.

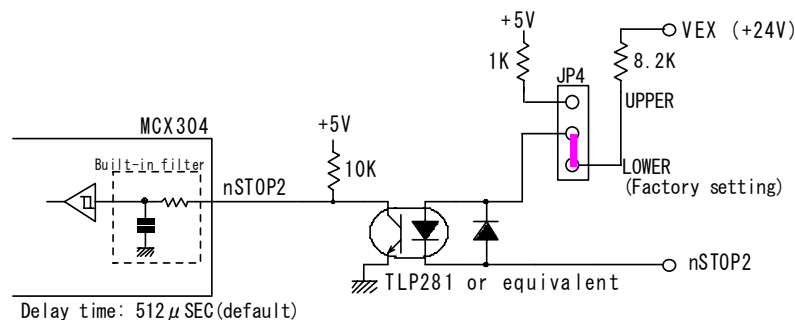

Encoder Z-phase Input Signal Circuit

#### [Notes on Z-phase search]

##### ■ Drive speed of Z-phase search

When this board is powered on, a built-in filter of nSTOP2 signal becomes the setting of signal delay time  $512\ \mu\text{sec}$  as default. In addition, TLP281 photo coupler (Toshiba) has approximately  $100\ \mu\text{sec}$  delay time, so that the drive speed to search Z-phase must be set for Z-phase signal to be active more than  $1\text{msec}$  at least. When noise circumstances are good, search operation can be performed at the higher speed by disabling the built-in filter of STOP2 signal.

##### ■ Starting position for Z-phase search

In automatic home search of MCX304, the function stops search driving when the Z-phase signal (nSTOP2) changes from inactive to active. Therefore, the starting position for Z-phase search must be completely away from this change point. Normally, adjust mechanically so that this starting position becomes the  $180^\circ$  opposite side to the encoder Z-phase position.

The connection example of nSTOP2 input signal and open collector output of an encoder is shown below. When open collector output is ON at Z-phase detected, set the D4 bit (SP2-L) of WR1 register to 0 (state of reset) for logical setting of MCX304.

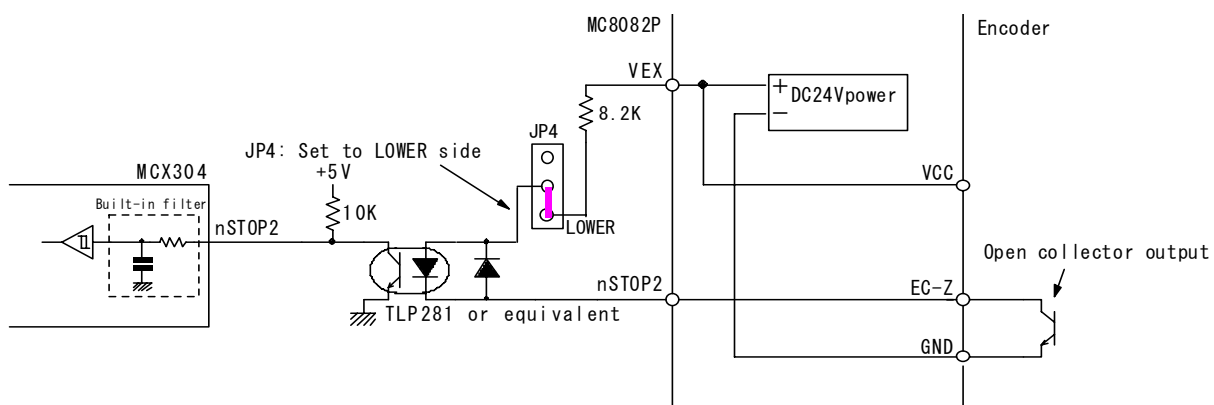

The following is the connection example of nSTOP2 input signal and one pin of line-driver output of an encoder. When output is low level at Z-phase detected, set the D4 bit (SP2-L) of WR1 register to 0 (state of reset) for logical setting of MCX304.

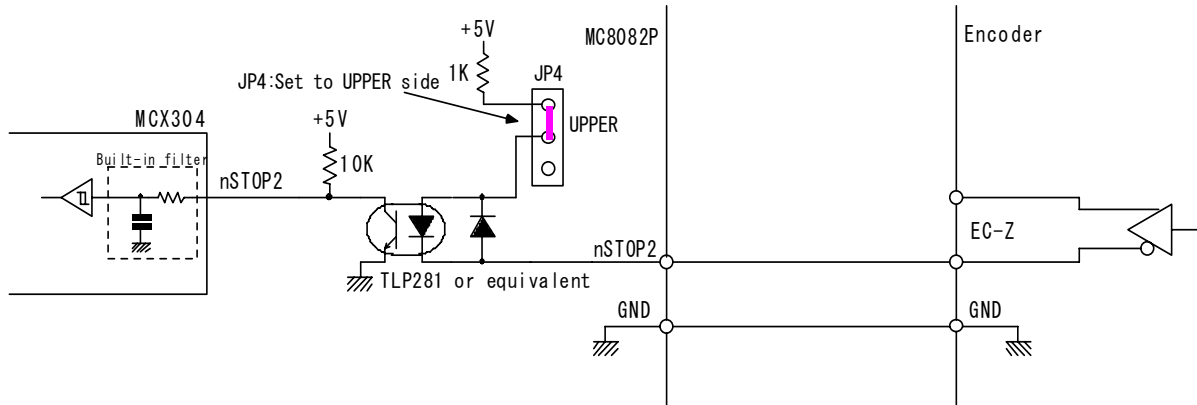

Connection Example with Z-phase Output of line-driver

### 3.8 Input Signals for Servo Motor (nINPOS, nALARM)

nINPOS input signal is applied to the in-position output of a servo motor driver. Enable/disable and logical level can be set in mode setting of MCX304. When enable is set and after completion of the driving, nDRV bit of main status register (RR0) returns to 0 after this signal becomes active.

nALARM input signal is applied to the alarm output from a servo motor driver. Enable/disable and logical level can be set in mode setting. When enable is set, nALARM input signal is monitored, and when nALARM is active, the ALARM bit of status register 2 (nRR2) is set to 1. When the signal becomes active during driving, driving will stop immediately.

After resetting, both signals are disabled. For nINPOS input signal, set the D15, 14 bit of mode register 2 (nWR2) of MCX304 to 1,0 as low active, and the n-DRV bit of RR0 register returns to 0 after waiting to flow current from nINPOS signal. For nALARM input signal, set the D13, 12 bit of nWR2 register to 1,0 as low level active, and the signal becomes an alarm state when current flows from nALARM signal pin. For more details, see chapter 2.6.5 and 4.5 of MCX304 user's manual.

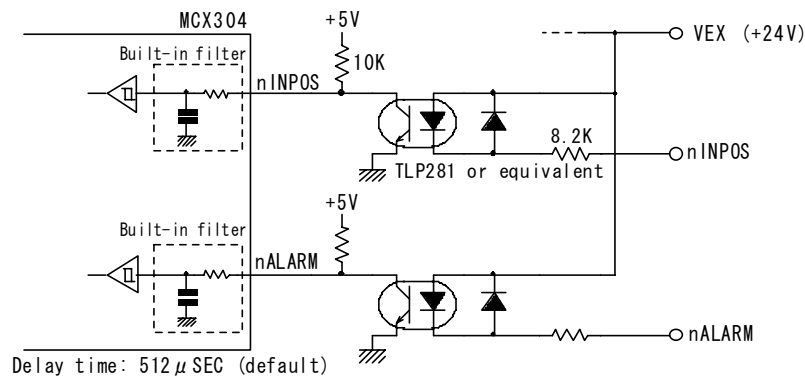

Input Signal Circuit for Servo Motor

To enable this signal, external power supply DC24V is needed. When the board is powered on, a built-in filter in this signal becomes the setting of signal delay time 512 μ sec as default. This signal delay time can be changed for circumstances of system noise. For more details, see chapter 2.6.9 and 4.6 of MCX304 user's manual.

In addition, the input signal for a servo motor can read out the signal status by input register 1, 2 (RR4, 5) at any time, so it can be used as general input.

### 3.9 Encoder A/B phase Input Signal (nECAP, nECAN, nECBP, nECBN)

nECAP/N, nECBP/N, input signals are the input to count a real position counter of MCX304 by connecting to the 2-phase output signal of an encoder or a servo motor driver. For more details, see chapter 2.3.1, 2.6.3 and 4.5 of MCX304 user's manual.

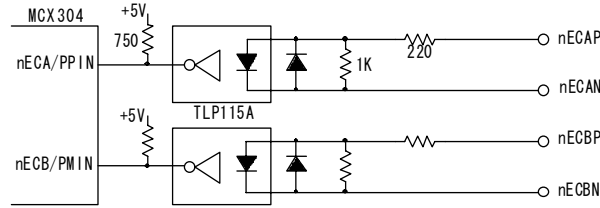

Encoder A/B phase Input Signal Circuit

As shown above, encoder A/B phase input signal circuit uses high-speed photo coupler IC TLP115A (Toshiba). Each input signal can be directly connected to a differential line-driver output. As the figure below, when n\*\*\*P/N signal is H/L, n\*\*\* signal of MCX304 becomes Low and when is L/H, it becomes Hi. The delay time from input to the signal pin of MCX304 is under 100nSEC, so that the signal can count up to 4MHz in the case of 2-phase pulse input.

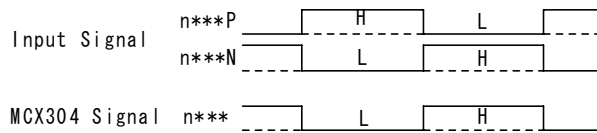

The connection example of an encoder A/B phase input signal and a differential line-driver output is shown as follows:

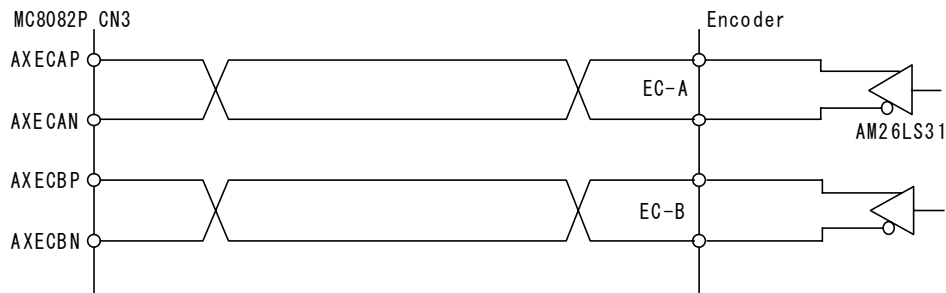

Connection Example with Differential line-driver Output

The connection example of an encoder A/B phase input signal and an encoder with open collector output is shown as follows:

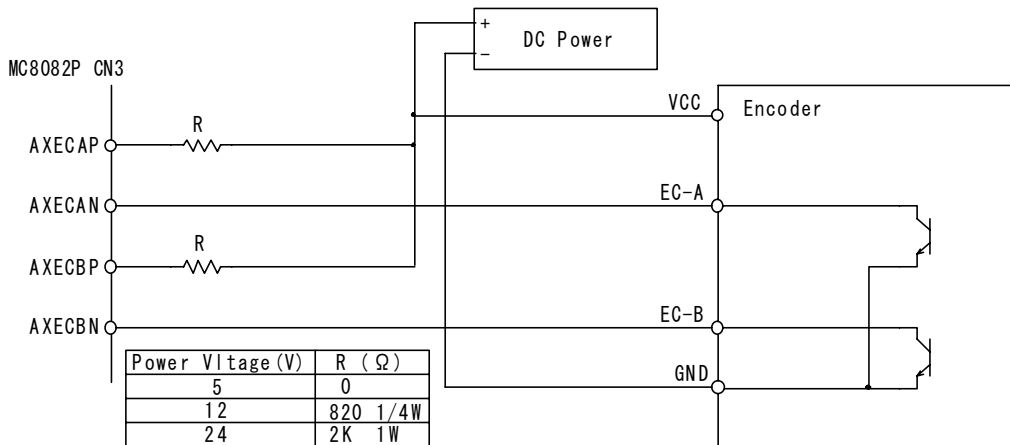

Connection Example with Open Collector Output

### 3.10 Driving by External Signal (nEXOP+, nEXOP-)

The signal externally controls driving in the + or - direction. In fixed driving mode, the falling edge of these signals trigger outputs specified drive pulse. In continuous driving mode, drive pulse is output continuously while the input signals are low. This function can reduce the load of the host CPU, so the user can perform jog feed of each axis speedy. External signal for driving can be set in mode setting of MCX304. For more details, see chapter 2.6.1 and 4.6 of MCX304 user's manual.

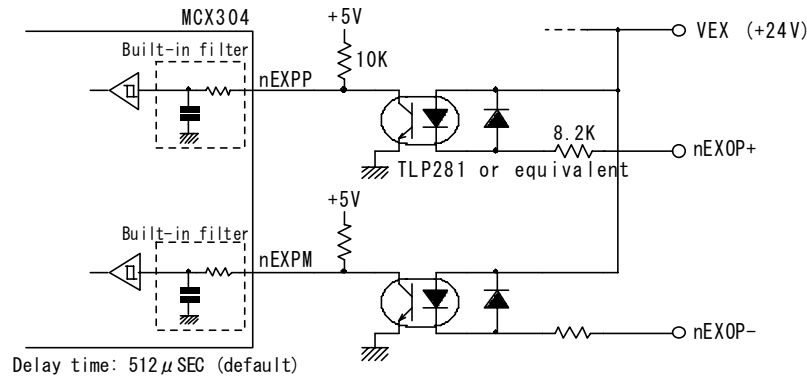

External Driving Signal(nEXOP+/-) Circuit

To enable this signal, external power supply DC24V is needed. When the board is powered on, a built-in filter in this signal becomes the setting of signal delay time 512 μ sec as default. This signal delay time can be changed for circumstances of system noise. For more details, see chapter 2.6.9 and 4.6 of MCX304 user's manual.

### 3.11 Emergency Stop Input Signal (EMG)

All the drive pulse output stops when emergency stop signal becomes active. Active level can be switched by the JP2 jumper pin on the board. When emergency stop signal becomes active during driving, driving for all axes stops instantly and 1 is set to the error bit of all axes of main status register. For emergency stop of MCX304, see chapter 2.6.6 and 4.1.2 of MCX304 user's manual.

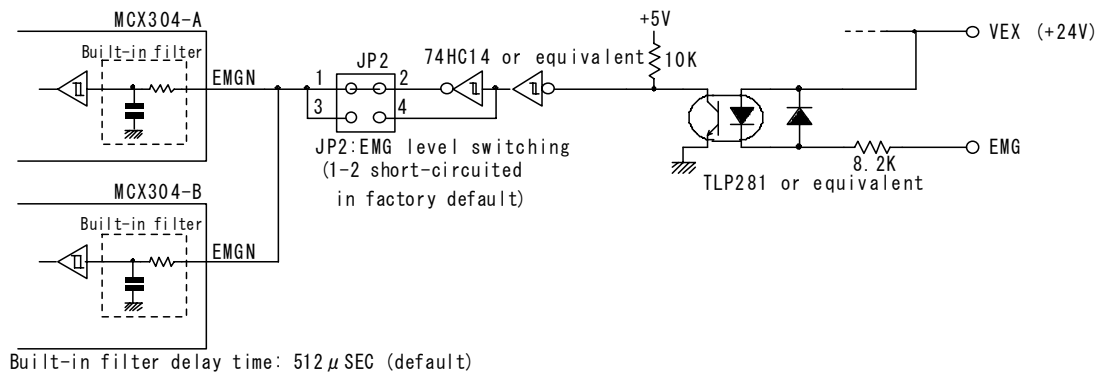

Emergency Stop Input Signal Circuit

To enable this signal, external power supply DC24V is needed. When the board is powered on, a built-in filter in this signal becomes the setting of signal delay time 512 μ sec as default. This signal delay time can be changed for circumstances of system noise. For more details, see chapter 2.6.9 and 4.6 of MCX304 user's manual.

- JP2
- |   |   |   |   |
|---|---|---|---|
| 1 | ○ | ○ | 2 |
| 3 | ○ | ○ | 4 |
- Pin assignments of the JP2 jumper is shown on the left.
  - 1-2 short circuit: When emergency stop signal (EMG) is short-circuited with GND of the external power, it becomes active.
  - 3-4 short circuit: When emergency stop signal (EMG) is open, it becomes active.
  - Factory default is 1-2 short-circuited.

### 3.12 External Power (VEX)

The power supplied externally is used for over run limit input signal (nLMT+, nLMT-) of each axis, decelerating stop/instant stop (nSTOP0, nSTOP1, nSTOP2) input signal, input signal for servo motor (nINPOS, nALARM), external signal for driving (nEXOP+, nEXOP-) and emergency stop input signal (EMG). DC24V is needed. Consumption current is 2.8mA per 1 input signal.



## 4. Interrupt

---

This board has an interrupt signal generated by two MCX304, which connect to the INTA# of four interrupt request signals in the PCI bus. When an interrupt occurs in MCX304, the interrupt request signal of this board changes from Hi to Low. By reading out the status register 3 (nRR3) of the axis generated the interrupt, the interrupt request signal returns from Low to Hi.

For the interrupt function of MCX304, please refer to the following.

Article	Reference manual
Function of the interrupt	Chapter 2.5 of MCX304 user's manual
Setting of the interrupt enable / disable	Chapter 4.4 of MCX304 user's manual
Interrupt notion to the application	MC8000P User's manual of device driver When handling the interrupt by VC in Chapter 3.4.3
Reading out of the interrupt generation	Chapter 4.13 of MCX304 user's manual MC8000P User's manual of device driver When handling the interrupt by VC in Chapter 3.4.3

### [Notes for using interrupt]

IRQ number for the interrupt signal of this board is determined depending on PnP function.

In addition, it shares the same interrupt request signal with other devices by PnP function and Windows, competition is not occurred because Windows generally controls it.

## 5. Connection Example for Motor Driver

### 5.1 Connection Example for Stepper Motor Driver

The figure shown below illustrates the connection example of MC8082P AX axis and the 5-phase micro step driver of TECHNO DRIVE KR535M.

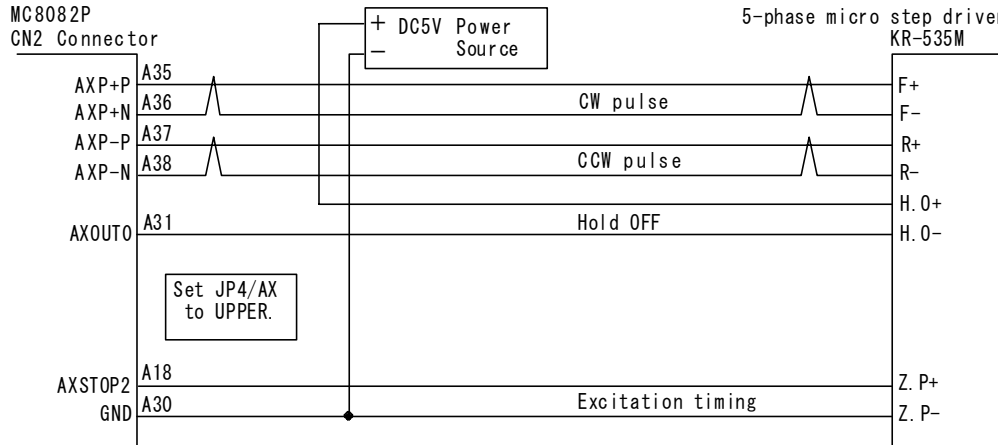

Note1: Wire hold OFF and excitation timing signals according to need. The hold off signal can be controlled by writing 0, 1 into the D0 bit of MCX304 WR4 register after the D0 bit of WR5 register is 1 for enabling XOUT0 signal. The excitation timing signal can perform a home search by the mode setting of WR1 register D4, 5 bit. In addition, the excitation timing signal can directly read out the signal level through the RR4 register.

The figure shown below illustrates the connection example of MC8082P AX axis and the stepper motor driver of Oriental Motor UPK series.

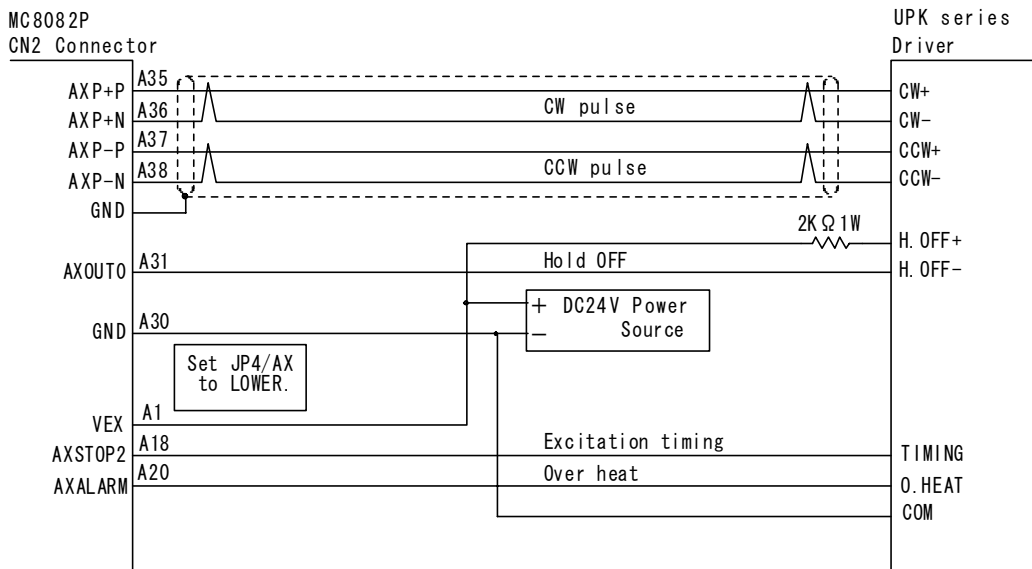

Note1: Wire hold OFF, excitation timing and over heat signals according to need. The hold off signal can be controlled by writing 0, 1 into the D0 bit of MCX304 WR4 register after the D0 bit of WR5 register is 1 for enabling XOUT0 signal. The excitation timing signal can perform a home search by the mode setting of the WR1 register D4, 5 bit. The over heat signal can perform an alarm function by the mode setting of the WR2 register D12, 13 bit. In addition, the excitation timing and over heat signals can directly read out the signal level through the RR4 register.

Note2: When the circumstances are affected by strong noise or there is long distance to the driver, the twist pair shield cable shown above is recommended.

### 5.2 Connection Example for AC servo motor driver

The figure shown below illustrates the connection example of MC8082P AX axis and the AC servo motor driver of MINAS S series.

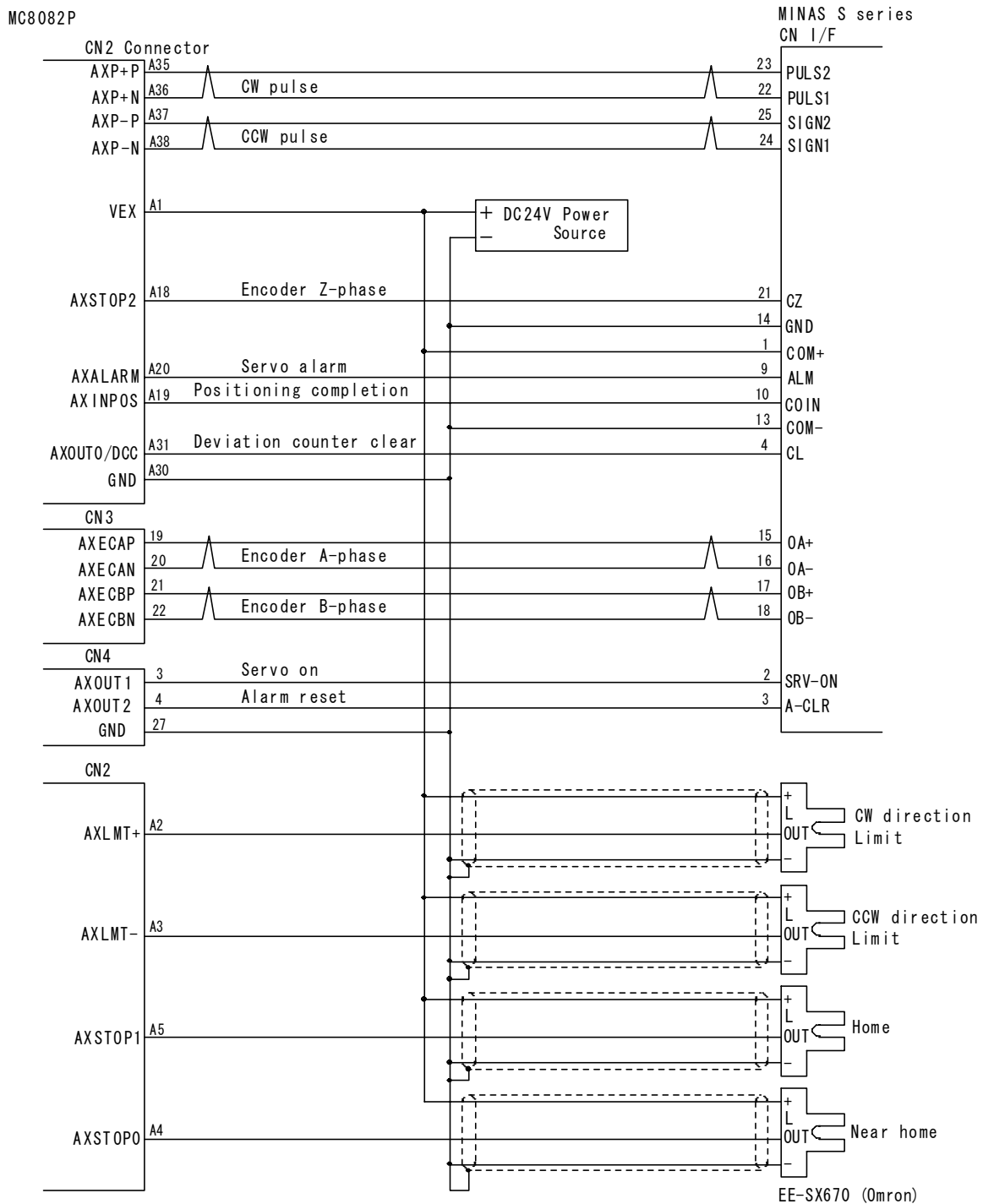

Note1: Set the mode of MINAS driver control to the position control mode and the pulse form to CW/CCW pulse mode. Do not set the pulse form to Pulse/Sign mode because the lack of t6 time occurs.

Note2: Use encoder A/B phase signals when the user counts a real position counter in MCX304. If the real position data is not necessary, no need to connect them. For other signals, connect them according to need.

Note3: In this example, encoder Z-phase uses the open collector output of driver side, so set JP4 to Lower side (default).

Note4: In this example, a near home signal and home signal are each connected for the home signal, so set JP3 to LOWER side (default).

Note5: When the circumstances are affected by strong noise or the distance to the driver is long, the twist pair shield cable shown above is recommended.

# 6. Input/Output Signals Timing

## 6.1 Reset

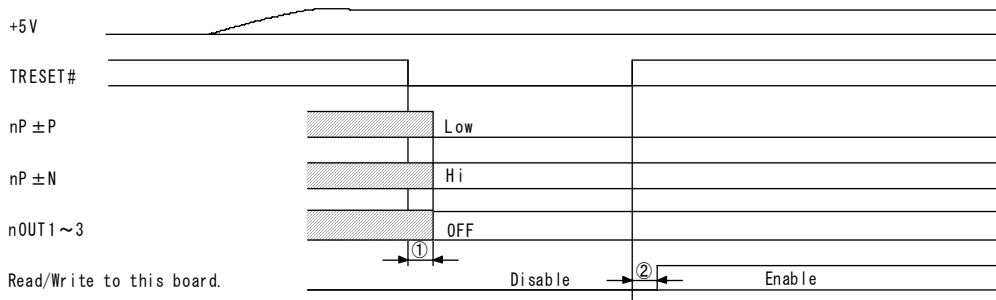

- ① Drive pulse output signals ( $nP\pm P$ ,  $nP\pm N$ ) and general output signals ( $nOUT1\sim 3$ ) are determined within a maximum of 250nSEC from ↓ of the target reset signal (TRESET#) of APIC21 (ADTEC).
- ② Writing/Reading to this board can be performed after 500nSEC from ↑ of the target reset signal (TRESET#).

## 6.2 Beginning of Driving

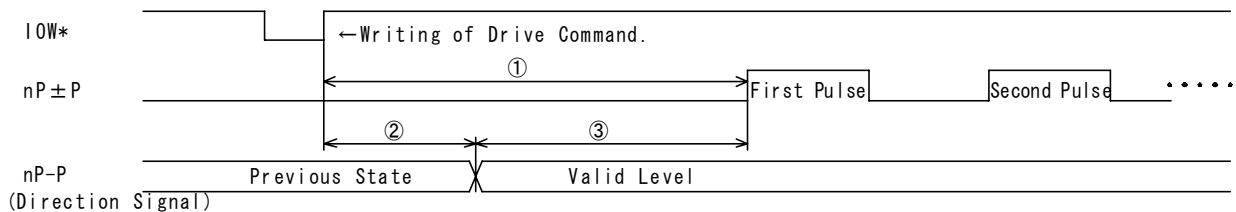

- ① First drive pulse is output within a maximum of 650nSEC after writing of drive command.
- ②③ When drive output pulse is 1-pulse type, a direction signal ( $nP-P$ ) becomes valid level within a maximum of 275nSEC after writing of drive command. And first drive pulse is output after 375nSEC when the direction signal becomes valid level.

## 6.3 Input Pulse Timing

### Encoder 2-phase Pulse Input

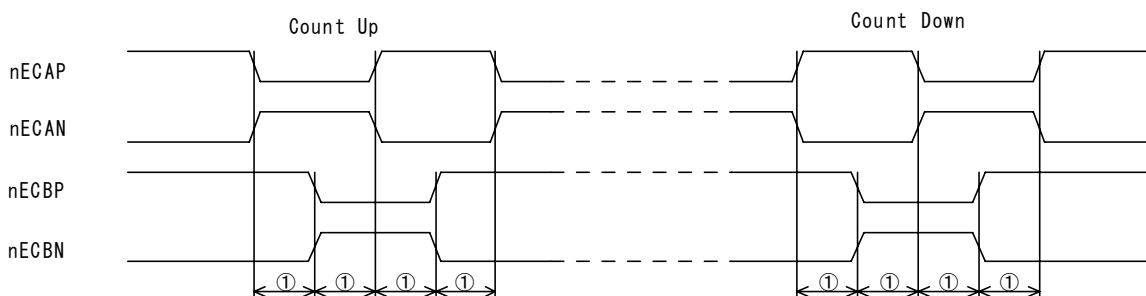

- ① EC-A,EC-B phase difference time : 200nSEC min.

■ Up/Down Pulse Input

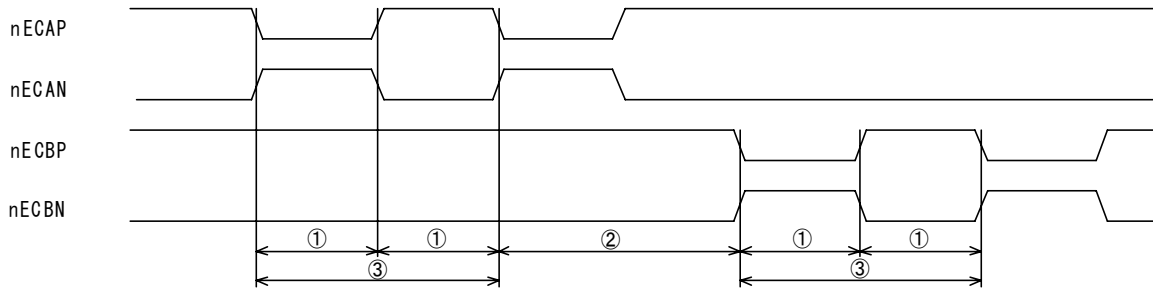

- ① UP/DOWN pulse width : 130nSEC min.
- ② UP⇔DOWN between the pulses : 260nSEC min.
- ③ UP/DOWN pulse cycle : 260nSEC min.

6.4 Instant Stop Timing

■ Instant Stop by External Signal

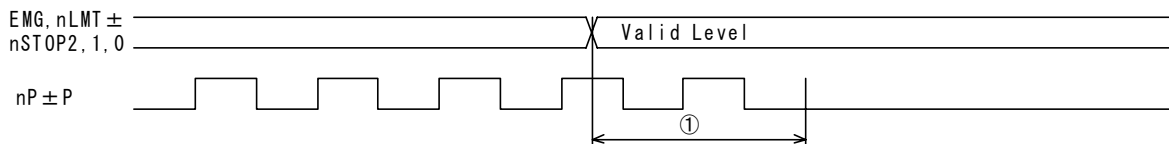

- ① When an external stop signal becomes valid level during driving, the driving stops after photo coupler delay time (100 μ sec max.) + the delay time of IC built-in integral filter (512 μ sec default) + 1 drive pulse.

■ Instant Stop by Command

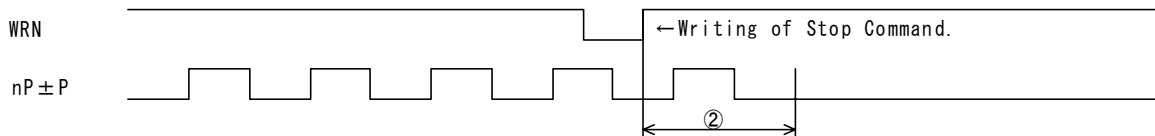

- ② When stop command is written during driving, the driving stops after a maximum of 1 drive pulse.

6.5 Decelerating Stop Timing

■ Decelerating Stop by External Signal

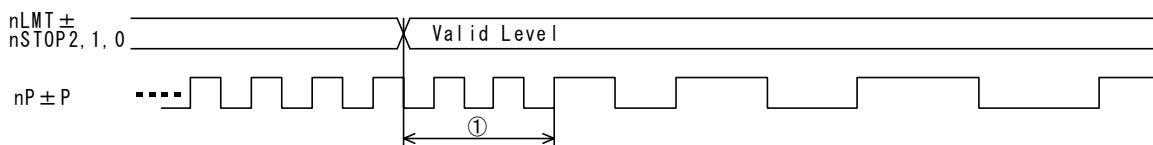

- ① When an external decelerating stop signal becomes valid level during driving, the driving starts deceleration after photo coupler delay time (100 μ sec max.) + the delay time of IC built-in integral filter (512 μ sec default) + 2 drive pulses.

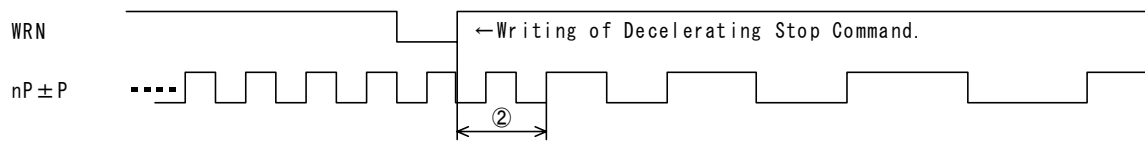
**■ Decelerating Stop by Command**

② When decelerating stop command is written during driving, the driving starts deceleration after a maximum of 2 drive pulses.

# 7. Board Dimensions

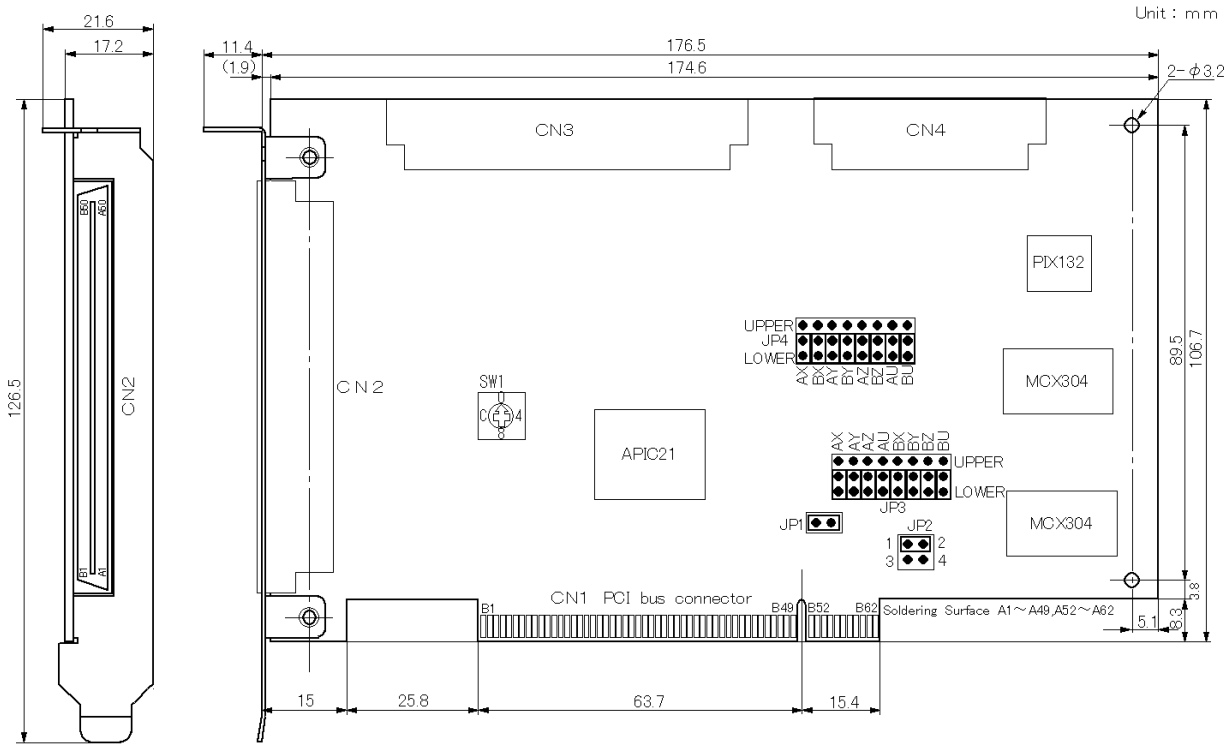

- JP1: Keep 1-2 short circuit (default).
- JP2: Select active logical level for emergency stop signal (EMG).
  - 1-2 short circuit (default): When the signal is short-circuited with GND, it becomes active.
  - 3-4 short circuit: When the signal is open, it becomes active.
- JP3: Select a home search signal. See chapter 3.6.
  - LOWER (default): Use STOP0 as a near home signal and STOP1 as a home signal.
  - UPPER: Use only STOP0 to perform high-speed home search → low-speed search.
- JP4: Select STOP2 (Encoder Z-phase) input circuit. See chapter 3.7.
  - LOWER (default): For the open collector output.
  - UPPER: For the line-driver output.
- SW1: Rotary switch to set the board number when multiple boards are used, which can be set from 0 to F (default setting: 0).

## 8. Specifications

---

- Control Axis 8 axes (Independent, Simultaneous Control)

### PCI Bus Interface

---

- Data Bit Width 16 bit
- Occupied I/O Address 64 Determined by PnP.
- Interrupt IRQ Determined by PnP.

### Common Specifications of Each Axis

---

#### ■ Drive Pulses Output

- Pulse Output Circuit Differential line-driver (AM26C31) output
- Pulse Output Speed 1PPS ~ 4MPPS
- Pulse Output Speed Accuracy  $\pm 0.1\%$  (according to the setting speed)
- Speed Multiplier 1 ~ 500
- S-curve Jerk 954 ~  $62.5 \times 10^6$  PPS/SEC<sup>2</sup> (Multiple = 1)  
477 x 10<sup>3</sup> ~ 31.25 x 10<sup>9</sup>PPS/ SEC<sup>2</sup> (Multiple =500)
- Accelerating / Decelerating Speed 125 ~ 1 x 10<sup>6</sup> PPS/SEC (Multiple = 1)  
62.5x10<sup>3</sup> ~ 500 x 10<sup>6</sup> PPS/ SEC (Multiple = 500)
- Initial Speed 1 ~ 8,000PPS (Multiple = 1)  
500PPS ~ 4x10<sup>6</sup> PPS (Multiple = 500)
- Drive Speed 1 ~ 8,000PPS (Multiple = 1)  
500PPS ~ 4x10<sup>6</sup> PPS (Multiple = 500)
- Output-pulse Number 0 ~ 268,435,455 (fixed drive)
- Speed Curve Constant speed, linear acceleration/deceleration, parabola S-curve acceleration/deceleration drive
- Fixed Drive Deceleration Mode Auto (non-symmetrical trapezoidal acceleration is also allowed) / manual
- Output-pulse numbers and drive speeds changeable during the driving
- Independent 2-pulse system or 1-pulse 1-direction system selectable
- Logical levels of drive pulse selectable

#### ■ Encoder A/B phase Input

- Input Circuit High-speed photo coupler input. Connectable with differential line-driverr.
- A/B phase pulse style or Up/Down pulse style selectable
- Pulse of each single, double and quad count edge evaluation is selectable (2-phase pulse style).

#### ■ Position Counter

- Logic Position Counter (for output pulse) range -2,147,483,648 ~ +2,147,483,647
  - Real Position Counter (for input pulse) range -2,147,483,648 ~ +2,147,483,647
- To read / write data is always possible.

#### ■ Comparison Register

- COMP + Register Position comparison range -1,073,741,824 ~ +1,073,741,823
- COMP - Register Position comparison range -1,073,741,824 ~ +1,073,741,823
- Software limit functioned

#### ■ Automatic home search

- Automatic execution of Step 1 (high-speed near home search) → Step 2 (low-speed home search) → Step 3 (low-speed encoder Z-phase search) → Step 4 (high-speed offset drive). Enable/Disable of each step and search direction selectable
- Deviation counter clear output : Clear pulse width within the range of 10  $\mu$  ~20msec and logical level selectable

#### ■ Interrupt

- The factors of occurring interrupt:
  - ..start / finish of a constant-speed drive
  - ..end of the driving
  - ..transition to "position counter  $\geq$  COMP-"
  - ..transition to "position counter < COMP-"
  - ..transition to "position counter  $\geq$  COMP+"
  - ..transition to "position counter < COMP+"

Enable / disable for these factors selectable

#### ■ External Signal for Driving

- EXOP+ and EXOP- signals for fixed / continuous drive
- Input Circuit Photo coupler + IC built-in integral filter

#### ■ External Deceleration / Instant Stop Signal



- STOP0 ~ 2 3 points for each axis (STOP0:near home, STOP1:home, STOP2:encoder Z-phase input)
  - Input Circuit Photo coupler + IC built-in integral filter
- Enable / disable and logical levels selectable and can be used as general input.

#### ■ Servo Motor Input Signal

- ALARM (Alarm), INPOS (In Position Check)
  - Input Circuit Photo coupler + IC built-in integral filter
- Enable / disable and logical levels selectable

#### ■ Servo Motor Output Signal

- DCC (Pin shared between deviation counter clear output and OUT0)
- Output Circuit TD62503 output (open collector output)

#### ■ General Output Signal

- OUT0 ~ 3 4 points for each axis (Total:  $4 \times 8=32$  points)
- Output Circuit TD62503 output (open collector output)

#### ■ Limit Signals Input

- 1 point for each + and - direction
  - Input Circuit Photo coupler + IC built-in integral filter
- Logical levels and decelerating / instant stop selectable

#### ■ Emergency Stop Signal Input

- EMG 1 point for all axes
- Stop the drive pulse immediately for all axes and logical levels selectable by jumper on the board.
- Input Circuit Photo coupler + IC built-in integral filter

### Electrical Characters

---

- Temperature Range for Driving 0 ~ + 45°C (No condensation)
- Power Voltage for Driving +5V  $\pm$  5 % (Consumption current 700mA max.)
- External Supply Voltage +24V
- Board Dimensions 174.6  $\times$  106.7mm (Connectors and brackets excluded)
- I/O Connector Type
  - CN2:FX2B-100PA-1.27DS (Hirose)
  - CN3:HIF3FC-50PA-2.54DS (Hirose)
  - CN4:HIF3FC-30PA-2.54DS (Hirose)
- Accessories
  - CN2:FX2B-100SA-1.27R (Hirose) with 1.2m cable
  - CN3:HIF3BB-50D-2.54R (Hirose) connector only
  - CN4:HIF3BA-30D-2.54R (Hirose) connector only