**SH-2 (SH7085) CPU Board
with LCD Controller**

CPU-328LTAD-Q (320*240DOTS TFT LCD)

Instruction Manual
(First Edition)

12/2011

Table of Contents

■ Safety Precautions	
· Safety Precautions	· · · · · P3
· Installation and Software Design Precautions	· · · · · P5
· Warranty and Disclaimer	· · · · · P7
■ Overview and Features of Product	
1. List of Accessories	· · · · · P8
2. Name and Function for the Circuit Board Connectors	· · · · · P8
3. Intended Purpose of Product	· · · · · P9
4. Main Features	· · · · · P10
■ Basic Specifications (SPEC)	
1. Electrical Specifications	· · · · · P11
2. Specifications for Short Pins and Switches, etc.	· · · · · P12
3. CN1 Signal Table	· · · · · P14
4. CN2 Signal Table	· · · · · P15
5. CN3 Signal Table	· · · · · P16
6. CN4 Signal Table	· · · · · P17
7. CN5 Signal Table	· · · · · P17
8. CN6 Signal Table	· · · · · P18
9. CN10 Signal Table	· · · · · P19
10. CN11 Signal Table	· · · · · P19
11. CN8 Signal Table	· · · · · P19
12. Address Map	· · · · · P20
13. Selection and Preparation of Peripheral Parts	· · · · · P21
14. Technical Documentation about the Product	· · · · · P21
Appendix 1. Dimensional Drawing of the Board	· · · · · P22

■ Safety Precautions

In order to prevent physical harm and property damage to those using and/or installing this circuit board device (the “Product”), the manual describes below the necessary safety precautions.

- The severity of harm and damage caused by incorrect usage or installation stemming from ignoring the directions herein are indicated by the following symbols and warnings.



This symbol indicates that the possibility of death or serious injury is imminent.



This symbol indicates that death or serious injury is possible.



This symbol indicates that minor injury or damage to only property is possible.

- The types of necessary precautions are classified according to the following symbols. (The symbols below are an example)



This symbol indicates "Prohibited" actions.



This symbol indicates "Mandatory" actions.



Danger



Do not breathe in or swallow the liquid crystal if the LCD is damaged and leaking. If the liquid crystal is sticking to your hands or clothes, wipe with alcohol etc., and wash thoroughly with water.



Warning



Always use a rated power supply device as per this manual.
Other devices may cause burnout and fire.



When installing, select a well-ventilated and dry area with no risk of water spillage. Otherwise, electrocution, electrical leakage, burnout, or fires may result.

■ Installation and Software Design Precautions

This section covers the precautions when installing the Product (CPU-328LTAD-Q and accompanying LCD panel and touch panel).

Installing the LCD and the PCB

- In order to protect the polarization plate and LCD, place the guard plate on the panel whenever possible.
- Avoid applying external pressure on the LSI when installing.
- Be careful not to warp or contort the LCD panel and PCB.
- When designing your product, assure that the size of the window frame is within the effective display area.
- When using a frame beyond the effective display area for the external appearance of your product, any non-uniform appearance of the product is beyond the scope of the warranty.
- It is possible that there is a burr on the frame edge of the LCD module.
When designing your product, be careful of any contact with cables so as to prevent damage to the cable insulation.

Static Electricity Precautions

- As CMOS-IC is used in the device, take proper measures to deal with static electricity when handling.
- Consider grounding for workers handling the device. For example, the use of an anti-static wrist strap/mat is recommended.

Handling Precautions

- Avoid placing in areas with high humidity for long periods of time. Be particularly careful of high humidity when the temperature is over 40 degrees Celsius.
- As the LCD polarization plate is easily damaged, be careful when handling. Avoid contact with hard objects.

-
- When cleaning the LCD surface, wipe lightly with a soft cloth (chamois leather, absorbent cotton etc.) and a drop of petroleum benzene.
 - When saliva or a drop of water remains on the LCD polarization plate for a long time, deformation, discoloration, staining, or fading may occur. Wipe away quickly.
 - As the LCD contains glass, chipping and cracking can occur when dropped or hit with a hard object.
 - When testing, avoid condensation in the device in order to avoid staining of the polarization plate.

Operating Precautions

- The LCD controller mounted on this CPU board is a type that forwards configuration data from the flash memory inside the device to the SRAM.
After powering on, it starts quickly after disengaging the reset. However, the hard fill starts soon after powering on. When designing software, ensure that it checks the completion of the hard fill in the hard fill register before allowing read-write access.
- Use of the Product in non-intended, off-specification conditions can cause a decrease in lifespan and a deterioration of visual quality. Always use within specifications.
- Use of the Product in conditions below the rated temperature can cause deterioration of visual quality and/or the formation of air bubbles. Use of the Product in non-intended, off-specification temperatures, can lead to an irreversible change in LCD characteristics. Always use within specifications.
- When the display is subjected to a strong push, a warning light comes on. However, it will return back to normal when left for a while, or if it is rebooted.
- D.C. application causes deterioration of the LCD. Be particularly careful with the connection of the CN6 (interface connector to the LCD), to make sure the contact is complete and not partial.

Storage Precautions

- Store the LCD in a cool, dry place. When keeping the LCD in long-term storage, place in a dark area away from sunlight and fluorescent lighting.
- When storing the LCD and PCB individually, make sure the polarization plate or LSI does not come in contact with other objects.

■ Warranty and Disclaimer

Warranty

- From a manufacturing standpoint, in order to warrant the functionality and reliability of the Product, Kenic System (the “Company”) may issue a delivery specification to the purchaser of the Product (the “Customer”). The warranty covers the items outlined in the delivery specification.
- Any modifications to the Product by the Customer will not be covered by the warranty.

Disclaimer

The Customer agrees that the Company shall not be held liable for accidents and damages caused by the Product under the following circumstances.

- Use of the Product in conditions not specified in this instruction manual (the “Manual”).
- Breakdown or damage to the Product caused by third-party products not approved and provided by the Company.
- Maintenance and repair work using parts not approved by the Company.
- The Customer did not follow the precautions or operating instructions as set forth in the Manual.
- Use of the Product in situations where the power source, installation environment, and other conditions are beyond the specifications as outlined in the Manual.
- Accidents and damages caused by natural disasters such as fires, earthquakes, floods, and lightning storms.

※ Component specifications and external appearance may change without notice. However, if previously agreed to installation dimensions and electrical interface need to be changed due to unforeseen circumstances, the Company will contact the Customer to resolve the issue.

■ Overview and Features of the Product

1. List of Accessories

LED backlight power supply “KSLBC-3(D2)” with on-board.

Assembly cable for CN4 (one end left cut)

2. Name and Function for the Circuit Board Connectors

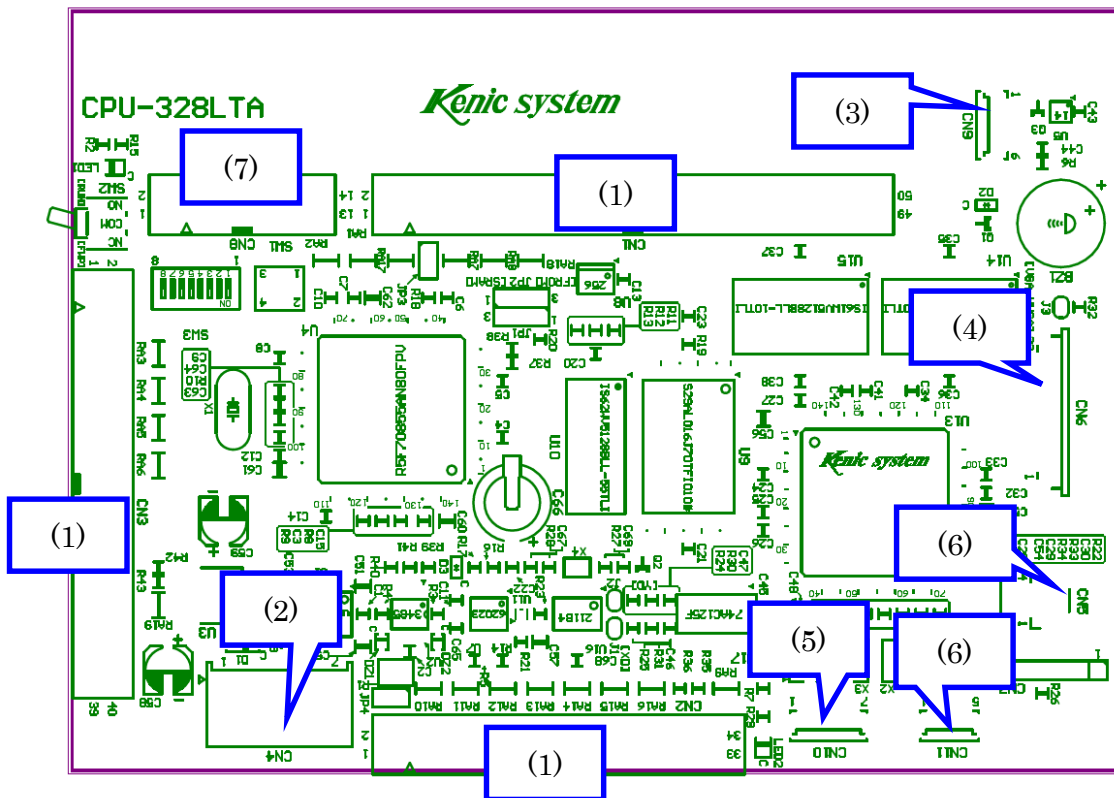

- (1) CN1, CN2, CN3: System expansion connectors for the CPU I/O or bus signals. (Almost any connector can be used, such as a flat cable connector, pin header, etc.)
- (2) CN4: Connector for RS-232C, RS-485 and +5V power supply.
- (3) CN9: Connector for backlight power supply.
- (4) CN6: Connector for LCD.
- (5) CN10: Write connector for touch panel controller (**KS-R8TPC**).
- (6) CN5, 11: Connector for touch panel.
- (7) CN8: Connector for H-UDI.

3. Intended Purpose of Product

The CPU328LTAD-Q is a TFT LCD-exclusive controller board for TFT color LCD display modules of the “LMTM057QVGNCA series” manufactured by DENSITRON, and the “GVTQ57NPAD series” manufactured by SGD.

Please refer to the following block diagram.

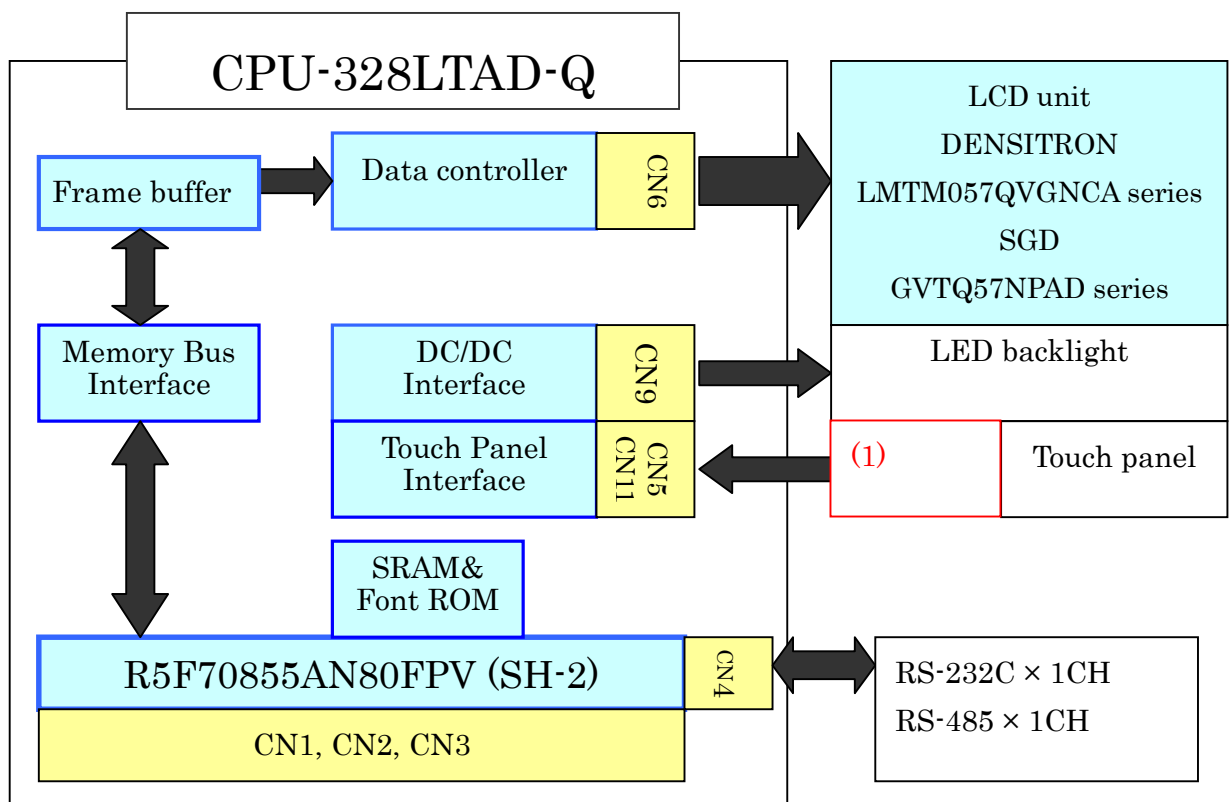

“(1)” is a touch panel connection substrate (model: CPU361L-TBS).

The substrate needs to connect the touch panel.

4. Main Features

- As the SH-2 (R5F70855AN80FPV) CPU by Renesas Technology is included as standard equipment, it is possible for the Customer's entire system to be completed with this single board.
- As the remaining I/O and bus signal have been extracted to a 2.54mm-pitch universal pattern, it is possible to directly install pin headers and flat cable connectors.
- One RS-232C line and one RS-485 line are included as standard equipment.
- Electronic buzzer is standard equipment.
- The Interface uses a CPU bus interface which can be directly connected with the CPU.

Easy interface is possible with the I/O port of the one-chip CPU.

It will be handled mostly the same as SRAM (static memory).

- 64 colors and 65,000 colors can be displayed per pixel. Additionally, there is a complete, one-to-one correlation between the mapping coordinates of the pixels and addresses as seen from the Customer's CPU.
- There is no lag for write to from the CPU at intervals of 200ns or longer.
There is no lag for read out at intervals of 400ns or longer.
Even under DMA with SH-2, there is plenty of latitude for access.
- Touch position data from the touch panel can be directly read out as 8-bit data.
- It is possible to set two different inverted color blink controls (two patterns).
- Full-screen wipe is supported by the hardware.
- It is possible to specify the color for wiping.
- As the CS0 area can be switched from the Flash-ROM area to the SRAM area using short pin, it is possible to debug by E10A, ICE, etc.
- As EEPROM is included, it is possible to hold data for memory.
- DC/DC power supply for the LCD backlight (LED backlight) is standard equipment.
- Compact and lightweight, the Product dimensions are 144mm×104.6mm (not including protruding cables).

Specifications differ depending on the target controller. For details, refer to the LCD Controller IC manual.

■ Basic Specifications

1. Electrical Specifications

—— LCD Section ——

- Intended LCD module CPU-328LTAD-Q:
LMTM057QVGNCA series (DENSITRON)
GVTQ57NPAD series (SGD)
- Intended LCD controllers KS-LDTQ-2PI
- Intended touch panel The above LCD is included as standard equipment.
- Intended touch panel controller KS-R8TPC (Kenic system)
- Intended backlight power supply KSLBC-3 (D2) (Kenic system)
- Frame buffer two pages
- Color representation 64 colors or 65,000 colors

—— CPU Section ——

- CPU R5F70855AN80FPV (Renesas)
- SRAM IS62WV5128BLL-55TLI (ISSI) etc.
- Flash-ROM S29AL016D90TFI01 (SPANSION)
etc.
- EEPROM 24LC256-I/SN (Microchip)
- Chinese character fonts JIS level-1, JIS level-2 (16dot font)
- RS-232C 1CH already mounted
- RS-485 ADM3485EARZ (Analog Devices)
1CH already mounted.
- Electronic buzzer TMB-05 (Star Micronics)

—— I/O Specifications ——

- CN1 For expansion bus: A0~A22, D0~D7, WAIT, CS3~4, WRL, RD, RESET, MRESET, BACK, BREQ
- CN2 For expansion bus: D8~D31, CK, NMI, WRH, WDTOVF
WRHH, WRHL
- CN3 For generic I/O: PE0~7, PF0~7,
PA2, 16, 21, 24, 25, PB5, PE15

— Others —

- Power supply Specifications

5V single supply 2.0A MAX

Rated voltage of CPU board 5V±0.25V

Consumption current of CPU board 200mA

*Not including LCD and backlight power supplies.

- Operating environment 0 °C~50 °C (CPU board only)

Refer to starter kit manual for operating temperature range when including LCD.

- External dimensions and weight

144 × 104.6 × 12.8mm

(not including protruding cables)

About 72g

2. Specifications for Short Pins and Switches, etc.

(1) JP1 For selecting CS0 area

Shorting between No. 1 and No. 2: CS0 is set in Flash-ROM area.

Shorting between No. 2 and No. 3: CS0 is set in SRAM area.

Caution) To avoid damage, do not set in the same area as CS1.

(2) JP2 For selecting CS1 area

Shorting between No. 1 and No. 2: CS1 is set in SRAM area.

Shorting between No. 2 and No. 3: CS1 is set in Flash-ROM area.

Caution) To avoid damage, do not set in the same area as CS0.

(3) JP3 For H-UDI

When open, CPU operates normally.

When short, it is the setting for H-UDI.

(4) JP4 For RS-485 terminator

When open, terminator is OFF.

When short, terminator is ON.

(5) J1 For switching the X axis data of the touch panel.

When short, the X axis data of the touch panel is reversed.

(6) J2 For switching the Y axis data of the touch panel.

When short, the Y axis data of the touch panel is reversed.

-
- When connecting to QVGA LCD (Kyocera), J2 is open.
- (7) SW1 Reset switch
When pressing SW1, set the RESET pin for the CPU, LCD controller,
etc. LOW.
- (8) SW2 For switching modes
When switched towards a lit LED1, CPU changes to boot mode.
When switched towards an unlit LED1, CPU operates normally.
- (9) SW3 8-bit DIP switch
Connected to the CPU I/O ports PF0~7.

3. CN1 Signal Table (Connector not mounted)

Pin number	Name of signal	Function
1,2	VCC	Pin for power. +5V supply pin.
3,4	VCC	Pin for power. +3.3V supply pin.
5	D0	Data bus of CPU.
6	D1	
7	D2	
8	D3	
9	D4	
10	D5	
11	D6	
12	D7	
13	CS3	CS3 of CPU
14	CS4	CS4 of CPU
15	RD	RD of CPU
16	WRL	WRL of CPU
17	/WAIT	WAIT of CPU. This pin is connected by open drain from LCD controller.
18	RESET	RESET of CPU
19,20	GND	Pin for power. Ground connection pin.
21	A0	Address bus of CPU.
22	A1	
23	A2	
24	A3	
25	A4	
26	A5	
27	A6	
28	A7	
29	A8	
30	A9	
31	A10	
32	A11	
33	A12	
34	A13	
35	A14	
36	A15	
37	A16	
38	A17	
39	A18	
40	A19	
41	A20	
42	A21	
43	A22	
44	MRESET	MRESET of CPU
45	BACK	BACK of CPU
46	BREQ	BREQ of CPU
47,48,49,50	GND	Pin for power. Ground connection pin.

Compatible connectors: Almost any 2.54-pitch, 50-pin pin headers and flat cable connectors.

4. CN2 Signal Table (Connector not mounted)

Pin number	Name of signal	Function
1,2	VCC	Pin for power. +3.3V supply pin.
3	D8	Data bus of CPU
4	D9	
5	D10	
6	D11	
7	D12	
8	D13	
9	D14	
10	D15	
11	D16	
12	D17	
13	D18	
14	D19	
15	D20	
16	D21	
17	D22	
18	D23	
19	D24	
20	D25	
21	D26	
22	D27	
23	D28	
24	D29	
25	D30	
26	D31	
27	WRH	WRH of CPU
28	NMI	NMI of CPU
29	WRHH	WRHH of CPU
30	WRHL	WRHL of CPU
31	WDTOVF	WDTOVF of CPU
32	CK	CK of CPU
33,34	GND	Pin for power. Ground connection pin.

Compatible connectors: Almost any 2.54-pitch, 34-pin pin headers and flat cable connectors.

5. CN3 Signal Table (Connector not mounted)

Pin number	Name of signal	Function
1,2	VCC	Pin for power. +3.3V supply pin.
3	PE0	CPU I/O port PEXX
4	PE1	
5	PE2	
6	PE3	
7	PE4	
8	PE5	
9	PE6	
10	PE7	
11,12	GND	Pin for power. Ground connection pin.
13	PF0	CPU I/O port PFXX
14	PF1	
15	PF2	
16	PF3	
17	PF4	
18	PF5	
19	PF6	
20	PF7	
21,22	AVSS	Analog GND
23,24	AVCC	Analog VCC (+5V)
25,26	VCC	Pin for power. +3.3V supply pin.
27	PA2	CPU I/O port PA2
28	N.C	No connection
29	N.C	No connection
30	PE15	CPU I/O port PE15
31	PA21	CPU I/O port PA21
32	PA25	CPU I/O port PA25
33	N.C	No connection
34	PA24	CPU I/O port PA24
35	PA16	CPU I/O port PA16
36	N.C	No connection
37	N.C	No connection
38	PB5	CPU I/O port PB5
39, 40	GND	Pin for power. Ground connection pin.

Compatible connectors: Almost any 2.54-pitch, 40-pin pin headers and flat cable connectors.

6. CN4 Signal Table for RS-232C, RS-485 Connectors

Pin number	Name of signal	Function
1	VCC	Power supply pin +5V
2	A	RS-485 sending/receiving (non-inverted)
3	TxD1	RS-232C sending line (in conjunction with program download)
4	B	RS-485 sending/receiving (inverted)
5	RxD1	RS-232C receiving line (in conjunction with program download)
6	GND	RS-232C signal ground
7	GND	Power supply pin 0V

Connector used: S7B-XH-A (LF) (SN) (JST Mfg. Co., Ltd.)

Compatible connector: XHP-7 (JST Mfg. Co., Ltd.)

7. CN5 Signal Table for Touch Panel Connector

Pin number	Name of signal	Function
1	XR	Touch panel signal XR
2	YU	Touch panel signal YU
3	XL	Touch panel signal XL
4	YL	Touch panel signal YL

Connector used: 04FFS-SP-TF (LF) (SN) (JST Mfg. Co., Ltd.)

8. CN6 Signal Table for LCD Connector

CN6		
Pin number	Name of signal	Function
1	GND	GND pin
2	CLK	Data sampling clock signal
3	Hsync	Horizontal sync signal (negative polarity)
4	Vsync	Vertical sync signal (negative polarity)
5	GND	GND pin
6	R0	Red data signal (LSB)
7	R1	Red data signal
8	R2	Red data signal
9	R3	Red data signal
10	R4	Red data signal
11	R5	Red data signal (MSB)
12	GND	GND pin
13	G0	Green data signal (LSB)
14	G1	Green data signal
15	G2	Green data signal
16	G3	Green data signal
17	G4	Green data signal
18	G5	Green data signal (MSB)
19	GND	GND pin
20	B0	Blue data signal (LSB)
21	B1	Blue data signal
22	B2	Blue data signal
23	B3	Blue data signal
24	B4	Blue data signal
25	B5	Blue data signal (MSB)
26	GND	GND pin
27	ENAB	Horizontal display position signal (positive polarity)
28,29	VCC	Power input (+3.3V)
30	R/L	Horizontal inverse signal (L: normal, H: flip horizontal)
31	U/L	Vertical inverse signal (H: normal, L: flip vertical)
32	V/Q	VGA/QVGA switch signal (H: VGA, L: QVGA) It is LOW fixation. The LCD side of DENSITORN is NC.
33	GND	GND pin

Connector used: 08-6210-033-340-800A+ (ELCO)

Compatible FPC cable: 0.5mm pitch, 33 pin. No compatible product on the market.

9. CN10 Signal Table for Touch Panel Controller Write Connector.

Pin number	Name of signal	Function
1	VCC	+3.3V power supply pin
2	TPRES	Already connected to /RES pin of KS-R8TPC
3		No connection
4	MODE	Already connected to MODE pin of KS-R8TPC
5	P4-5	Already connected to P4-5 pin of KS-R8TPC
6	P3-7	Already connected to P3-7 pin of KS-R8TPC
7	GND	GND pin

Connector used: 53261-0771 (Molex)

10. CN11 Signal Table for Touch Panel Connector

Pin number	Name of signal	Function
1	XR	Touch panel signal XR
2	YU	Touch panel signal YU
3	XL	Touch panel signal XL
4	YL	Touch panel signal YL
5	NC	No connection

Connector used: 53261-0571 (Molex)

Compatible connector: 51021-0500 (Molex)

11. CN8 Signal Table for H-UDI Connector

Pin number	Name of signal	Function
1	TCK	H-UDI connection
2	NC	
3	TRST	
4	GND	
5	TDO	
6	GND	
7	ASEBRKA K	
8	VCC	
9	TMS	
10	GND	
11	TDI	
12	GND	
13	RESET	
14	GND	

Connector used: XG4C-1431 (Omron)

12. Address Map

**The on board CPU is preset so as to operate by mode2 (MD0=0 MD1=1).*

**The Chinese character ROM area, external RAM area, and LCD controller areas have not been decoded in the CS space.*

** For more details, refer to the HITACHI SH7080 series hardware manual.*

0000 0000H	ROM with built-in CPU	
0007 FFFFH	Free (Reserved for CPU)	
0200 0000H	Chinese character ROM	CS0 area
0207 FFFFH	Image	
0400 0000H	External RAM	CS1 area
0407 FFFFH	Image	
0800 0000H	Frame buffer for LCD controller	CS2 area
0801 DFFFH	Free	
0801 FFF9H	Various registers for LCD controller	
0801 FFFFH	Image	
0C00 0000H	Free space	CS3 area
1000 0000H	Free space	CS4 area
13FF FFFFH		

The frame buffer and the various registers differ depending on the LCD controller. Refer to the chip set manual for details.

13. Selection and Preparation of Peripheral Parts

(1) Selection of the main power supply device

Power-supply voltage: 5V±0.25V

Consumption current: 2.0A MAX

Boot speed: within 300mS

Ripple noise: within 150mV

** Much of this is consumed by the LED backlight power supply.*

(2) Connection of each unit

Refer to the starter kit manual for connecting each of the units.

Use only the minimum length necessary for cables. Unnecessarily long cables may cause a decrease in transmission speeds and/or introduce noise.

(3) Powering on the Product

Before powering on, carefully check all connections first. Loose connections may cause damage to parts.

14. Technical Documentation about the Product

Technical information about the Product is continually updated and posted on the Kenic system website. Please feel free to browse at the URL below.

<http://www.kenic.co.jp/w/>

