

MCX501 is 1-axis motion control IC which can control either stepper motor driver or pulse type servo motor for position and speed control and perform trapezoidal/S-curve precise and smooth acceleration/deceleration drive.

This IC is epoch-making motion control IC which is equipped with speed range-free, timer and split pulse as new functions.

MCX501 Functional Block Diagram

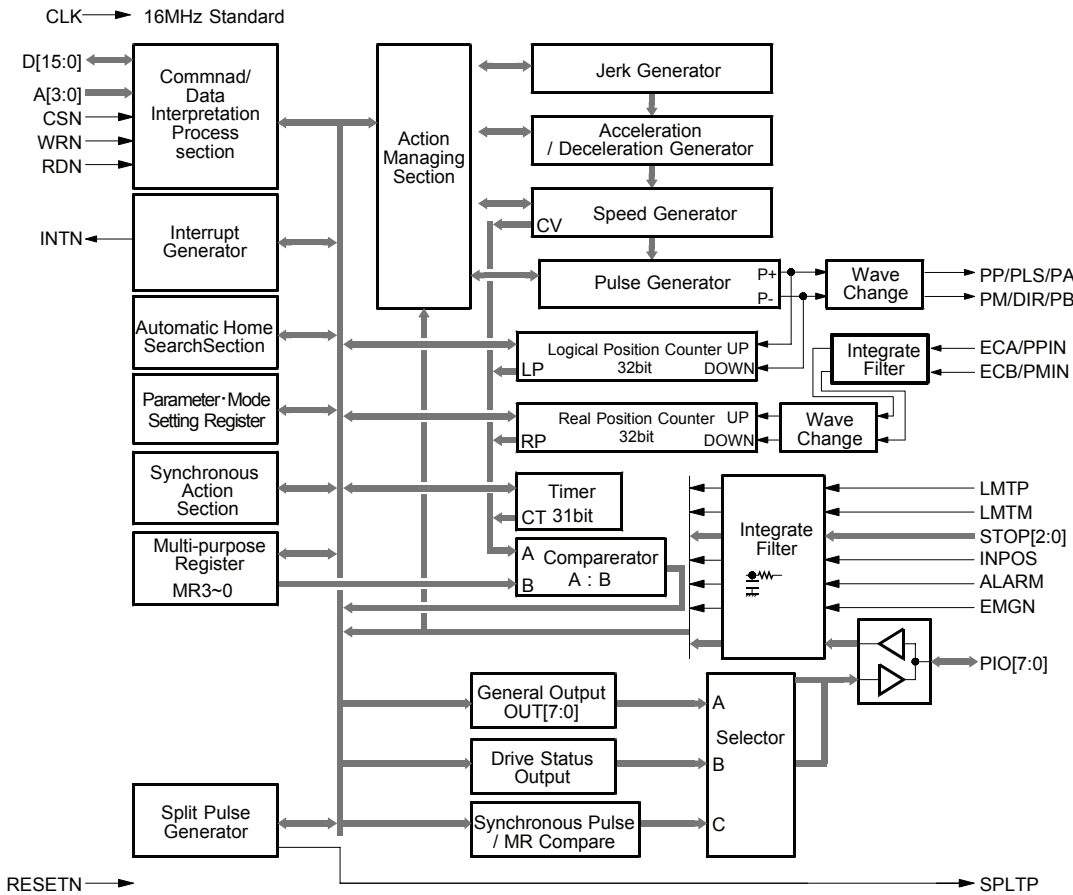

- 64pin plastic TQFP 0.5mm pin pitch
- Dimension(L×W×H) 10×10×1.0 mm
- RoHS compliant

Input/Output signal

Signal *1	Pin No.*2	Description
CLK(I)	46	Clock 16MHz(Standard)
D15/PIN7~D8/PIN0(B)	2~4,6~8, 11~12	Data Bus/Universal Input
D7~D0(B)	13,15~17, 20~22,24	Data Bus
A3~0(I)	25~28	Address
CNS(I)	29	Chip select
WRN(I)	30	Write strobe
RDN(I)	31	Read strobe
RESET(I)	32	Reset
H16L8(I)	33	16/8 Data bit bus width selection
TEST1/2(-)	59,62	Test
INTN(O)	34	Interrupt
PP /PLS /PA(O)	35	+ direction drive pulse /Drivepulse/A-phase signal
PM /DIR /PB(O)	36	- direction drive pulse /Direction/B-phase signal
ECA /PPIN(I)	37	Encoder A-phase /Up pulse
ECB /PMIN(I)	38	Encoder B-phase /Down pulse
STOP2~0(I)	39,40,42	Decelerating stop /Instant stop
LTMP(I)	43	+ direction limit

Signal *1	Pin No.*2	Description
LMTM(I)	44	- direction limit
INPOS(I)	48	In position
ALARM(I)	49	Servo alarm
PIO7 /ADSND /CMP3(B)	50	General input output 7 /Acceleration descend /Compare MR3
PIO6 /ACNST /CMP2(B)	51	Universal input output 6 /Acceleration constant /Compare MR2
PIO5 /EXPM /AASND /CMP1(B)	52	Universal input output 5 /External operation- /Acceleration ascend /Compare MR1
PIO4 /EXPP /DSND /CMP0(B)	53	Universal input output 4 /External operation+ /Descend/Compare MR0
PIO3 /CNST(B)	54	Universal input output 3 /Constant
PIO2 /ASND(B)	55	Universal input output 2 /Ascend
PIO1 /ERROR(B)	57	Universal input output 1 /Error
PIO0 /DRIVE(B)	58	Universal Input Output 0 /Drive
EMGN(I)	60	Emergency stop
DCC(O)	61	Deviation counter clear
SPLTP(O)	64	Split pulse

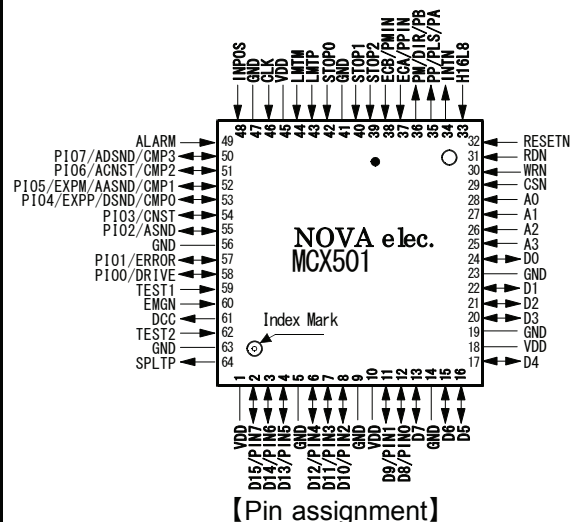

【Pin assignment】

【Note】

- \*1 Each I, O, and B means input, output and bi-directional.
- \*2 These terminals are used commonly by multi-functions, no. 2~4, 6~8, 11, 12, 35~38, 50~55, 57, 58.

## Speed range free

MCX501 can set the drive speed by a 1pps unit from 1pps to 8Mpps without range setting (range-free).

When setting the drive speed by using Multiple(Range setting),

- Setting Multiple small for precise speed setting at low speed  
→ It can not change to high speed drive.
- Setting Multiple large for high speed drive  
→ It can not set precise drive speed.

There were the above limitations for the previous ICs. By speed range free, such inconvenience has been taken away and MCX501 can change the speed directly from low speed, 1pps, 2pps to high speed pulse like 1Mpps during driving.

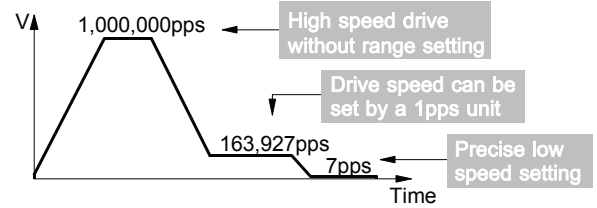

## Acceleration/deceleration driving

### ◆Acceleration/deceleration drive

MCX501 can perform multiple acceleration/deceleration driving, constant speed drive, trapezoidal acceleration/deceleration drive(symmetrical/non-symmetrical), S-curve acceleration/deceleration drive(symmetrical/non-symmetrical).

### ◆Automatic deceleration

In position drive of trapezoidal acceleration/deceleration (symmetrical/non-symmetrical), S-curve acceleration/deceleration (symmetrical only), MCX501 calculates the deceleration start point and starts deceleration drive automatically.

### ◆S-curve acceleration/deceleration

In S-curve acceleration/deceleration, a primary linear increase/decrease method is applied. Therefore the speed acceleration profile forms parabolic S curve. Triangle waveforms during S-curve acceleration/deceleration are prevented by a special method.

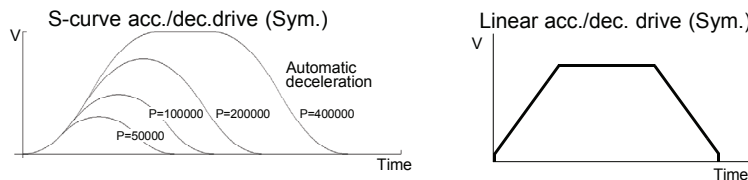

## Split pulse

MCX501 can output split pulses during driving. Synchronizing an axis's movement, various kinds of actions can be performed in specified intervals. Split length, pulse width and pulse numbers can be set. By combining the split pulse output and the synchronous action, start/stop split pulse from a specified position and split length and pulse width can be changed by external signal input.

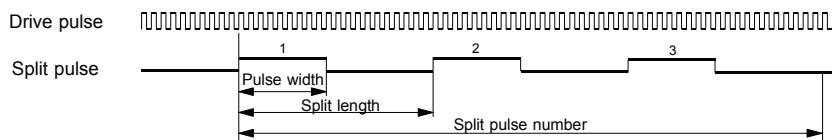

## Built-in timer

MCX501 is equipped timer. It can be set by a 1μsec unit 1 ~ 2,147,483,647μsec time range(at CLK=16MHz).

It can be performed the various actions precisely as follows by combining the timer and the synchronous action.

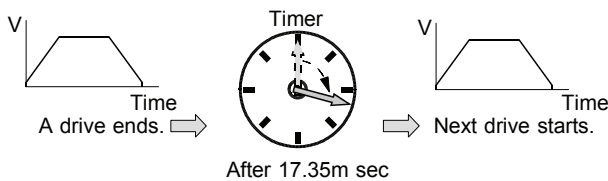

- After the driving is finished, start the driving after waiting a specified time.
- After the external signal is input, start the driving after waiting a specified time.
- Stop the continuous driving after waiting a specified time.
- Measuring the passing time from position A to B. and so on.

## Synchronous Actions

The synchronous action is a function that performs a specified action when a specified activation factor (provocative) occurs the axis or with a device outside of IC by linking with a provocative.

The specified action by the synchronous action is very fast and precise because there is not any intervention of CPU. It can be set 4 sets as synchronous action. 1set of synchronous action consists of a specified provocative and a specified action. 15 types of provocatives are available, passing the specified position, starting/stopping of driving, rising/falling of an external input signal, when the timer is finished and so on. 28 types of actions are available, start/stopping of driving, saving the value of the current position counter in the multi-purpose register, writing the drive speed and so on. More various applications can be performed by combining the plural synchronous actions. Also, repeat of action can be settable.

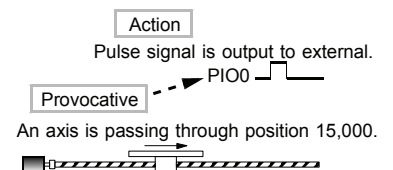

## Commands

## ■ Commands for data writing

Code	Commands	Symbol	Data range	Data length (byte)
00h	Jerk setting	JK	1 ~ 1,073,741,823 [pps/sec <sup>3</sup> ]	4
01	Deceleration increasing rate setting	DJ	1 ~ 1,073,741,823 [pps/sec <sup>2</sup> ]	4
02	Acceleration setting	AC	1 ~ 536,870,911 [pps/sec]	4
03	Deceleration setting	DC	1 ~ 536,870,911 [pps/sec]	4
04	Initial speed setting	SV	1 ~ 8,000,000 [pps]	4
05	Drive speed setting	DV	1 ~ 8,000,000 [pps]	4
06	Drive pulse number /Finish point setting	TP	-2,147,483,646 ~ +2,147,483,646	4
07	Manual deceleration point setting	DP	0 ~ 4,294,967,292	4
09	Logical position counter setting	LP	-2,147,483,648 ~ +2,147,483,647	4
0A	Real position counter setting	RP	-2,147,483,648 ~ +2,147,483,647	4
0B	Software limit + setting	SP	-2,147,483,648 ~ +2,147,483,647	4
0C	Software limit - setting	SM	-2,147,483,648 ~ +2,147,483,647	4
0D	Acceleration counter offsetting	AO	-32,768 ~ +32,767	2
0E	Logical position counter maximum value setting	LX	1 ~ 2,147,483,647(7FFF FFFFh) or FFFF FFFFh	4
0F	Real position counter maximum value setting	RX	1 ~ 2,147,483,647(FFF FFFFh) or FFFF FFFFh	4
10	Multi-purpose register 0 setting	MR0	-2,147,483,648 ~ +2,147,483,647	4
11	Multi-purpose register 1 setting	MR1	-2,147,483,648 ~ +2,147,483,647	4
12	Multi-purpose register 2 setting	MR2	-2,147,483,648 ~ +2,147,483,647	4
13	Multi-purpose register 3 setting	MR3	-2,147,483,648 ~ +2,147,483,647	4
14	Home detection speed setting	HV	1 ~ 8,000,000 [pps]	4
15	Speed increasing / decreasing value setting	IV	1 ~ 1,000,000 [pps]	4
16	Timer value setting	TM	1 ~ 2,147,483,647 [ $\mu$ sec]	4
17	Split pulse setting 1	SP1	Split length: 2 ~ 65,535 Pulse width: 1 ~ 65,534	4
18	Split pulse setting 2	SP2	Split pulse number: 0 ~ 65,535	2

## ■ Commands for data reading

Code	Commands	Symbol	Data range	Data length (byte)
30h	Logical position counter reading	LP	-2,147,483,648 ~ +2,147,483,647	4
31	Real position counter reading	RP	-2,147,483,648 ~ +2,147,483,647	4
32	Current drive speed reading	CV	0 ~ 8,000,000 [pps]	4
32	Current acceleration/deceleration reading	CA	0 ~ 536,870,911 [pps/sec]	4
34	Multi-purpose register 0 reading	MR0	-2,147,483,648 ~ +2,147,483,647	4
35	Multi-purpose register 1 reading	MR1	-2,147,483,648 ~ +2,147,483,647	4
36	Multi-purpose register 2 reading	MR2	-2,147,483,648 ~ +2,147,483,647	4
37	Multi-purpose register 3 reading	MR3	-2,147,483,648 ~ +2,147,483,647	4
38	Current timer value reading	CT	0 ~ 2,147,483,647 [ $\mu$ sec]	4
3D	WR1 setting value reading	WR1	(Bit data)	2
3E	WR2 setting value reading	WR2	(Bit data)	2
3F	WR3 setting value reading	WR3	(Bit data)	2
40	Multi-purpose register mode setting reading	MRM	(Bit data)	2
41	PIO signal setting 1 reading	P1M	(Bit data)	2
42	PIO signal setting 2 and other settings	P2M	(Bit data)	2
43	Acceleration setting value reading	AC	1 ~ 536,870,911 [pps/sec]	4
44	Initial speed setting value reading	SV	1 ~ 8,000,000 [pps]	4
45	Drive speed setting value reading	DV	1 ~ 8,000,000 [pps]	4
46	Drive pulse number/finish point setting value reading	TP	-2,147,483,646 ~ +2,147,483,646	4
47	Split pulse setting 1 reading	SP1	Split length : 2 ~ 65,535 Pulse width : 1 ~ 65,534	4

## [Note]

- Unit of speed parameter value and timer value is used when CLK is 16MHz.

## ■ Mode writing command

Code	Commands	Symbol	Data length (byte)
20h	Multi-purpose register mode setting	MRM	2
21	PIO signal setting	P1M	2
22	PIO signal setting 2 and other settings	P2M	2
23	Automatic home search mode setting 1	H1M	2
24	Automatic home search mode setting 1	H2M	2
25	Input signal filter mode setting	FLM	2
26	Synchronous action SYNC 0 setting	S0M	2
27	Synchronous action SYNC 1 setting	S1M	2
28	Synchronous action SYNC 2 setting	S2M	2
29	Synchronous action SYNC 3 setting	S3M	2

## ■ Drive commands

Code	Commands
50h	Relative position drive
51	Counter relative position drive
52	+ direction continuous pulse drive
53	- direction continuous pulse drive
54	Absolute position drive
56	Drive decelerating stop
57	Drive instant stop
58	+ setting for direction signal
59	- setting direction signal
5A	Automatic home search execution

## ■ Synchronous action operating commands

Code	Commands
81~8Fh	Synchronous action enable setting
91~9F	Synchronous action disable setting
A1~AF	Synchronous action activation

## ■ Other settings

Code	Commands
70h	Speed increasing
71	Speed decreasing
72	Deviation counter clear output
73	Timer start
74	Timer stop
75	Split pulse start
76	Split pulse stop
79	Error finish status clear
1F	NOP
FF	Command reset

## Other Specifications

Control axis	1-axis	External signal for driving *4	·EXPP, EXPM signals for relative position drive and continuous drive.
Data bus	16/8 bit selectable	·Driving in manual pulsar mode(encoder input : quadrature single count edge evaluation)	
Drive pulse output pulse (When CLK is 16MHz.)		External stop signal	
●Drive speed range	1pps ~ 8Mpps *1	●3 points (STOP0~2)	
●Output speed accuracy	within ±0.1%(According to the setting value.)	●Enable/disable	Enable/disable for stop signal function is selectable. *5
●Position drive decelerating stop mode	Automatic/Manual *2	●Logical level	Low active/Hi active is selectable.
●Override	Output pulse number and drive speed during driving are changeable. *3	●Stop mode	When active, drive decelerating stop. (When lower than initial speed, driving stops immediately)
●Drive commands	Relative position drive, Absolute position drive, +/- direction continuous drive	Input signal for servo motor	
●Triangle form prevention	For both trapezoidal and S-curve acceleration/deceleration.	●Signal types	ALARM (Alarm), INPOS (In-position check), DCC (Deviation counter clear)
●Type of drive pulse output	Independent 2-pulse, 1-pulse 1direction, 2 phase double and quad count edge evaluation are selectable.	●Enable/disable	Enable/disable of signal is selectable.
●Drive pulse output logic	Positive logic or negative logic is selectable.	●Logical level	Low active/Hi active is selectable
●Drive pulse output terminal	Terminals can be replaced.	General output/input signal	
Encoder input		·8 points	
●Input pulse type	2-phase single, double, quad count evaluation edge, up/down pulse are selectable.	Drive status signal output *6	
●Input pulse terminal	Terminals can be replaced.	●Signal types	·Driving, error occurring, accelerating/constant speed driving/ decelerating, acceleration increasing/constant/decreasing.
Software limit		·Drive status can be readable by status register.	
●Stop mode	Decelerating/instant stop is selectable.	Over run limit signal input	
Multi-purpose register		●2 points (each + direction, - direction.)	
●Size·number	32-bit·4 pcs	●Enable/disable	Enable/disable for limit function is selectable. *4
●Usage	Comparison of position, speed and timer. Register of position and speed. Save the current position, speed and the value of timer during driving can be executed by combining the synchronous action.	●Logical level	Low active/Hi active is selectable.
Automatic home search		●Stop mode	When active, instant/decelerating stop is selectable.
●Sequence	STEP1 High-speed home search → STEP2 Low-speed home search → STEP3 Encoder Z-phase search → STEP4 Offset driving	●Input pulse terminal	Terminals are changeable.
·Enable/disable and search signal and direction for each step are selectable.		Emergency stop signal	
●Deviation counter clear output	Clear pulse width from range of 10μ ~ 20msec and logical level are selectable.	·EMGN 1 point	In Low level, stop drive pulse output. (Logical level can not be set.)
●Timer between steps	Selectable from the range of 1msec ~ 1,000msec.	Integral filter built-in	
Interrupt		●Input signal filter	Equip integral filter in input column of each signal.
●Interrupt factor		●Filter time constant	Selectable from 16types (500n,1μ,2μ,4μ,8μ,16μ,32μ,64μ, 128μ,256μ,512μ,1m,2 m,4 m,8 m,16 m[sec])
·When comparison of multi-purpose registers are changed.		●Enable/disable	Enable/disable of filter function is selectable.
1.Comparative object : Logical/real position counter value, current speed value, current timer value		Electrical characteristics	
2.Comparison condition : ≥, >, =, <		●Temperature range for operation	-40°C ~ +85°C
·When drive starts/stops, acceleration/deceleration drive starts/stops at constant speed area and so on.		●Power voltage	+3.3V ±10%
●Enable/disable		●Consumption current	27mA(Average) , 44mA(Max) at CLK=16MHz
·Valid/invalid for each interrupt factor is selectable.		●Clock	16MHz(Standard) , 20MHz(Max)
		●Input signla level	TTL level (5V tolerant)
		●Output signal level	3.3V CMOS level (Only TTL can be connect to 5V type.)

## &lt;Remarks&gt;

- \*1 At CLK=20MHz, maximum speed is 10Mpps.  
 \*2 Automatic decelerating stop is performed by calculating a start point of decelerating according to a specified moving pulse value inside IC. Manual decelerating stop is performed by upper CPU to decide a start point of decelerating. MCX501 can perform automatic decelerating stop except non-symmetrical S-curve acceleration/deceleration.  
 \*3 Change of output pulse numbers after driving starts is possible only for the same direction relative position drive.  
 \*4 Terminal of External signal input is commonly used with general input/output.  
 \*5 When this function is not used, it can be used as general input.  
 \*6 Terminal of drive status output is commonly used with general input/output.

The Specifications are subject to change without notice due to the technical improvement.

2012.1

Distributor

中国一级代理商



达格美 (上海) 集成电路有限公司  
 TAKUMI (SHANGHAI) INTEGRATED CUICUIT CO.,LTD.

地址: 上海市浦东新区张杨路188号汤臣中心B栋801室  
 电话: 021-5840-8299 E-mail: dgms@takumi-hkg.com  
 传真: 021-5840-1590 WEB: www.takumi-sh.com



NOVA electronics, Inc.

3F, Grand Axe Bldg., 1-7-20 Uehara, Shibuya-Ku, Tokyo 151-0064, Japan  
 WEB SITE <http://www.novaelec.co.jp/eng/index.html>  
 EMAIL ADDRESS [novaelec\\_info@novaelec.co.jp](mailto:novaelec_info@novaelec.co.jp)  
 TEL 81-3-5738-3666 FAX 81-3-5738-3665