

MCX312 is 2-axis motion control IC which can independently control each 2-axis of either stepper motor driver or pulse type servo motor for position and speed control. In addition, it can perform 2-axis linear, circular and bit pattern interpolation (bit pattern interpolation is executed by bit data from CPU). Multichip axes linear interpolation is also possible.

Specification

- Control axis 2 axes
- Data bus width 16/8 bit selectable

Interpolation

- Interpolation command linear interpolation, CW/CCW circular interpolation, 2-axis bit pattern interpolation
- Interpolation range each axis -8,388,608 ~ +8,388,607
- Interpolation speed 1PPS ~ 4MPPS
- Interpolation position accuracy (within the whole range) ±0.5LSB(Linear interpolation), ±1 LSB(Circular interpolation)

Related functions for interpolation

Constant vector speed, continuous interpolation, single step interpolation and multichip axes linear interpolation

Common specifications of each axis

- Drive output pulse (at CLK 16MHz.)
- Output speed range 1 PPS ~ 4 MPPS
- Output speed accuracy ±0.1%(according to the setting value)
- S-curve jerk 954 ~ 31.25×10⁶ PPS/SEC²
- Accelerating/deceleration speed 125 ~ 500×10⁶ PPS/SEC
- Initial speed 1 ~ 4×10⁶ PPS
- Drive speed 1 ~ 4×10⁶ PPS
- Output pulse number 0 ~ 268,435,455 (Fixed pulse drive) or unlimited (Continuous drive)
- Speed curve

Constant, linear acceleration/deceleration or parabola S-curve acceleration/deceleration

Deceleration mode for fixed pulse

- Auto(Non-symmetry linear interpolation is allowed)/manual
- Output pulse number and speed are changeable during the driving.
- Independent 2 pulse system or 1pulse 1direction system is selectable.
- Logical levels of pulse are selectable.
- Encoder input pulse
- 2 phase pulse style or Up/Down pulse style is selectable.
- 2 phase pulse single, double or quad counter edge evaluation is selectable.
- Position counter
- Logical position counter(for output pulse) -2,147,483,648 ~ +2,147,483,647
- Real position counter(for input pulse) -2,147,483,648 ~ +2,147,483,647
- Comparison register
- COMP+ register comparison range -1,073,741,824 ~ +1,073,741,823
- COMP- register comparison range -1,073,741,824 ~ +1,073,741,823
- Status and signal outputs for the comparisons of position counters.
- To work as software limit

Interrupt factors (Interpolation excluded)

- the start/finish of a constant-speed drive during the acceleration/deceleration driving
- the end of the driving
- transition to "position counter ≥ the volume of COMP-
- transition to "position counter < the volume of COMP-
- transition to "position counter ≥ the volume of COMP+
- transition to "position counter < the volume of COMP+

External signal for driving

EXPP and EXPM signal for +/- direction fixed/continuous pulse drive. Driving in manual pulsar mode(Encoder input).

External decelerating/instant stop signal

STOP0 ~ 2 3 points for each axis. Enable/disable and logical levels are selectable.

Input signal for servo motor

ALARM(Alarm) and INPOS(In position check)

General input/output signal

IN0 ~ 5 6 points for each axis (4 points of them are pin sharing with multichip interpolation signal)

OUT0 ~ 7 8 points for each axis

(Pin sharing with drive status output signal)

Drive status output signal

DRIVE(Driving), ASND(Accelerating), DSND(Decelerating), CMPPP(Position≥COMP+), CMPPM(Position<COMP-), ACASND(Increasing of accelerating/decelerating speed) and ACDSND(Decreasing of accelerating/decelerating speed).

Limit signal input

1 point for each +/-direction

Logical levels and decelerating/instant stop are selectable.

Emergency stop signal

EMGN 1 point for all axes

Stop the drive pulse of all axes immediately in Low level.

Integral filter built-in.

Equipped integral filter in the input column of each input signal.

One time constant can be selected from 8 types.

Electrical characteristic

- Temperature range for operating 0 ~ +85°C
- Power voltage +5V ±5%(max.50mA)
- Input/output signal level CMOS or TTL connectable
- Input clock 16,000 MHz(Standard)
- Package 100 pin plastic QFP pin pitch=0.65
- External size(including pins) 23.8×17.8×3.05 mm

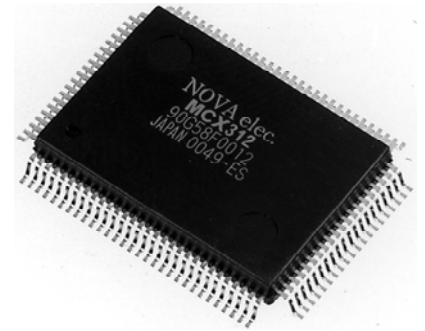

MCX312 Functional Block Diagram

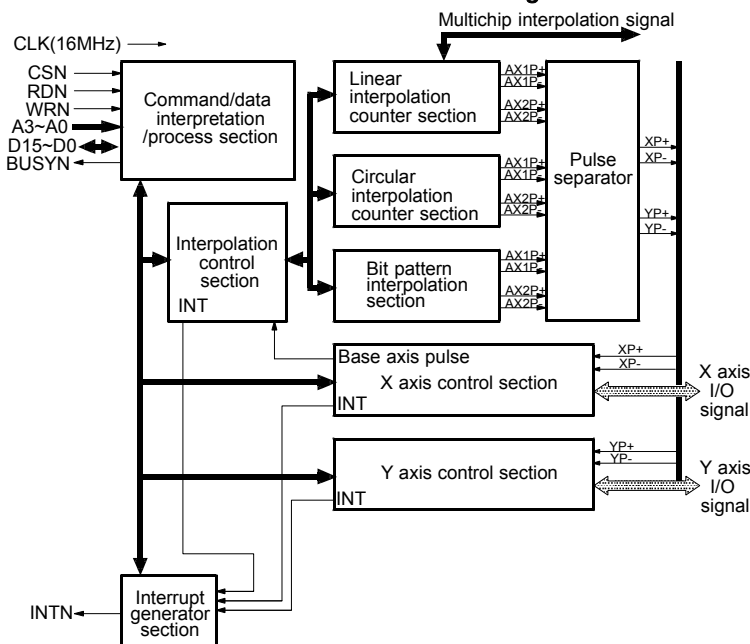

The block diagram of the whole function of MCX312

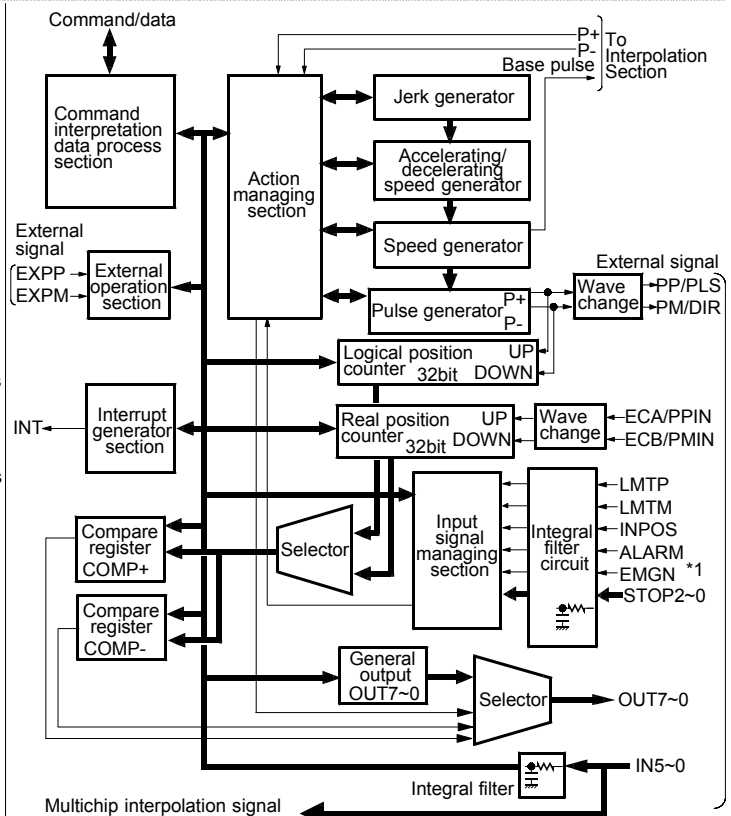

Block Diagram of the X and Y-axis Control Section

2-axis independent motion control

MCX312 has 32 bit position counter for each X and Y axis and function to drive constant speed, linear and S-curve acceleration/deceleration to maximum speed 4MPPS.

Drive command is operated by +/- direction fixed pulse drive or continuous drive basically.

● Fixed pulse: Output the specified pulse number.

● Continuous pulse: Keep outputting the pulse unlimitedly until the stop factor is generated.

Either drive can be operated in constant speed and linear /S-curve acceleration/deceleration by action parameter and mode setting.

■ S-curve acceleration/deceleration drive

In S-curve acceleration/deceleration driving, automatic deceleration is available for symmetrical S-curve only and triangle forms during S-curve acceleration/deceleration are prevented by a special method as the right figure however the number of output pulse is small.

■ Automatic deceleration of non-symmetry trapezoidal drive
Automatic deceleration can be operated on linear acceleration/deceleration drive whose accelerating and decelerating speed are different. It doesn't need for users to set the start point of deceleration by manual.

【Note】 In case of acceleration > deceleration, there is a limiting point of the rate of deceleration/acceleration to execute decelerating automatically. Limitation depends on driving speed. For instance, when drive speed is 100kpps, its limitation is 1/40.

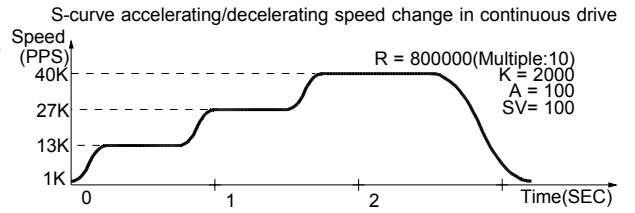
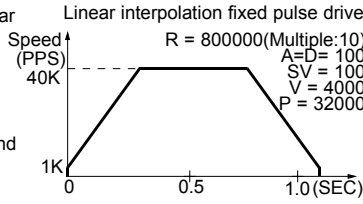
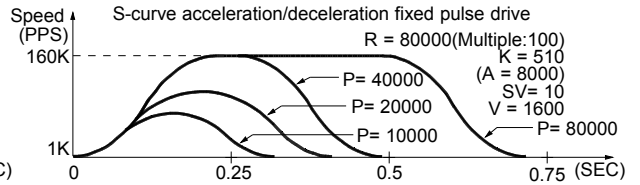
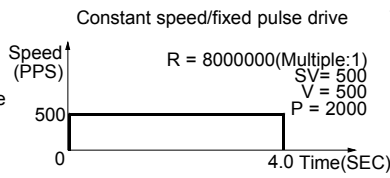

Non-symmetry trapezoidal acceleration/deceleration drive (acceleration < deceleration)

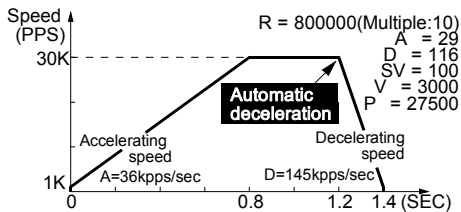

Non-symmetry trapezoidal acceleration/deceleration drive (acceleration > deceleration)

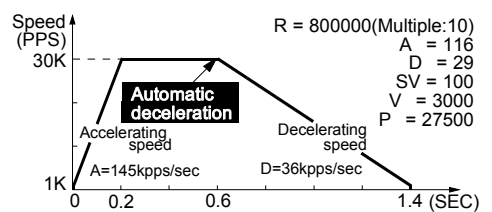

Built-in integral filter

Signals of limit and driving stop for each axis are influenced by external noise. To cut these noises, photo coupler or CR integral filter is mounted on the circuit normally. However MCX312 is equipped with integral type filters in the input stage of each input signal. It is possible to set a number of input signals whether the filter function is enabled or the signal is passed through. A filter time constant is selectable from eight stages.

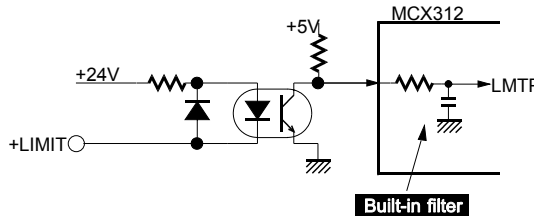

FL2~0	Delay time of input signal
0	2 μ SEC
1	256 μ SEC
2	512 μ SEC
3	1.024mSEC
4	2.048mSEC
5	4.096mSEC
6	8.192mSEC
7	16.384mSEC

Interpolation

■ 2-axis linear interpolation

Linear interpolation is executed by writing linear interpolation command after setting speed parameter of X-axis and the point coordinates of X and Y to the present point coordinates. Linear interpolation moves from the present point coordinates to the finish point. Interpolation range of each axis is -8,388,607 ~ +8,388,607. Interpolation accuracy to the specified line is ±0.5 LSB or less within the whole range. Interpolation drive speed is 1PPS ~ 4MPPS.

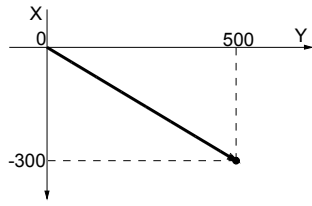

Fig.1 Example of 2-axis linear interpolation

【Setting procedure for the operation of Fig.1】

- ① Range XR= 8,000,000 (Speed Multiple:1)
- ② Initial speed XSV= 1000
- ③ Drive speed XV= 1000 (1000PPS)
- ④ Finish point XP= 500
- ⑤ Finish point YP=-300
- ⑥ 2-axis linear interpolation drive

■ Circular interpolation

Circular interpolation is executed by writing CW or CCW circular interpolation command after setting the center and finish point coordinates to the present point (the start point). CW circular interpolation is starting from the present point to the finish point with clockwise direction, to the contrary, CCW circular interpolation drives to counterclockwise direction. The perfect circle appears by setting (0,0) to the finish point. The range of interpolation coordinates is -8,388,608 ~ +8,388,607 from the present point. The position tolerance for specified circular curve is ±1 LSB within the whole interpolation range. Interpolation drive speed is 1PPS ~ 4MPPS (at CLK=16MHz).

【Setting procedure for the operation of Fig.2】

- ① Range XR= 8,000,000 (Speed multiple:1)
- ② Initial speed XSV= 500
- ③ Drive speed XV= 500 (500PPS)
- ④ Center point XC= -10000
- ⑤ Center point YC= -10000
- ⑥ Finish point XP= 0
- ⑦ Finish point YP= -20000
- ⑧ CCW circular interpolation drive

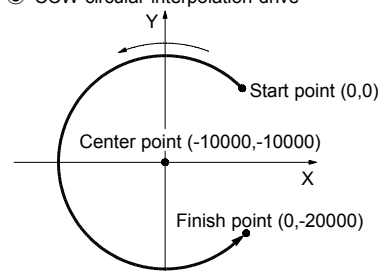

Fig.2 Example of CCW circular interpolation

【Setting procedure for the operation of Fig.3】

- ① ~ ③ Same as Fig.2
- ④ Center point XC= 5000
- ⑤ Center point YC= 0
- ⑥ Finish point XP= 0
- ⑦ Finish point YP= 0
- ⑧ CW circular interpolation drive

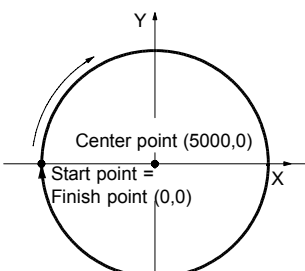

Fig.3 Example of CW circular interpolation

■ Continuous interpolation

Continuous interpolation executes the sequence of interpolation drive continuously. During the continuous interpolation, the driving will not stop; contrarily, the pulses are output continuously. When executing the continuous interpolation, the host CPU has to write the next interpolation segment into MCX312 before the previous interpolation segment is finished. Fig.4 shows the example of continuous interpolation from segment 1 to segment 8 of which start point is (0,0). In segment 1,3,5 and 7, linear interpolation is executed. In segment 2,4,6 and 8, circular interpolation is executed of which tracks are quadrant circle with radius 1500.

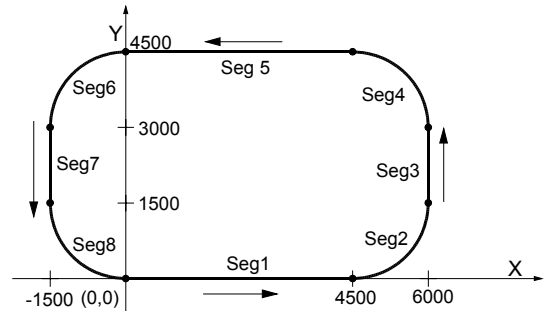

Fig.4 Example of continuous interpolation

■ Multichip axes linear interpolation

This function is multichip axes linear interpolation using several chips of MCX312. Fig.5 shows the example of connecting for 4 axes linear interpolation using 2 pieces of MCX312. Transfer the data of interpolation via 8 signals for multichip interpolation (pin sharing with general input signal).

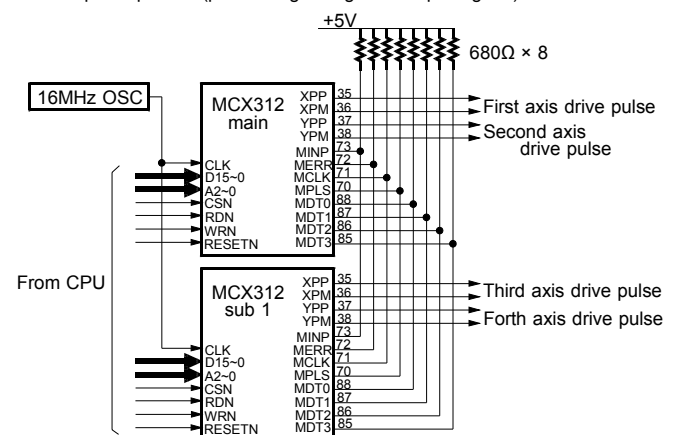
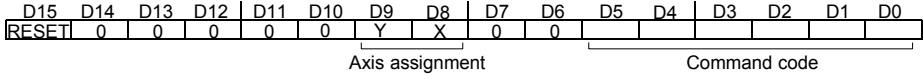
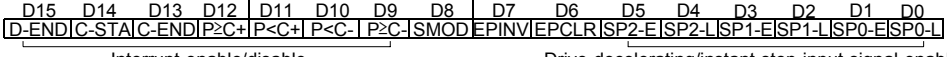
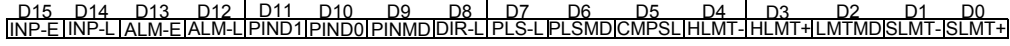
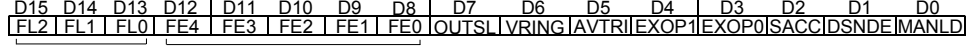
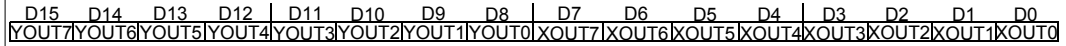
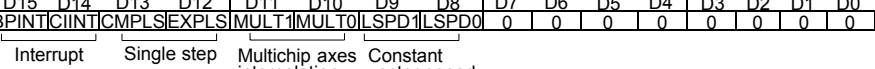

Fig.5 Example of connecting multichip axes interpolation

■ Input/Output signals (I: Input O: Output B: bidirectional Each X and Y axis has nOOO signal. "n" means each X and Y axis.)
 ●CLK(I) Clock 16MHz(Standard) ●D15~0(B) Data Bus ●A3~0(I) Address ●CSN(I) Chip select ●WRN(I) Write strobe ●RDN(I) Read strobe ●RESETN(I) Reset ●H16L8(I) 16/8 Data bit bus width selection ●BUSYN(O) Executing the command ●INTN(O) Interrupt ●SCLK(O) 1/2CLK ●nPP/PLS(O) + direction drive pulse/Drive pulse ●nPM/DIR(O) - direction drive pulse/Direction ●nECA/PPIN(I) Encoder A-phase/Up pulse ●nECB/PMIN(I) Encoder B-phase/Down pulse ●nOUT7~0(O) General output (DSND: Decelerating, CNST: Constant speed driving, ASND: Accelerating, DRIVE: Outputting drive pulse, CPM: P<COMP-, CMP: P>COMP+, ACDSND: Decreasing accelerating/decelerating speed, and ACASND: Increasing accelerating/decelerating speed, pin sharing with drive status output) ●nINPOS(I) In-position for servo driver ●nALARM(I) Servo driver alarm ●nLMTP(I) + direction limit ●nLMTM(I) - direction limit ●nSTOP2~0(I) 3points for decelerating/instant stop ●nEXPP(I) External + direction drive, manual pulsar A-phase ●nEXPM(I) External -direction drive, manual pulsar B-phase ●EMGN(I) Emergency stop ●nIN5~0(I) 6points for general input(nIN5~2 are pin sharing with multichip interpolation signal.)

■ Write register

Address			Symbol	Register name	Contents
A2	A1	A0			
0	0	0	WR0	Command register	Writing of the command in each axis and interpolation control section.  ●D9~8 Axis assignment 0:non-select/1:select(Several axes selectable simultaneously) ●D15 1:Reset
0	0	1	XWR1 YWR1	X axis mode register 1 Y axis mode register 1	Setting of the logical levels and enable/disable of external decelerating/instant stop, interruption enable/disable for each axis and operation mode of the real position counter.  ●D5~0***-E 0:disable/1:enable ***-L Logical level 0:Low/1:Hi ●D6:Real position counter is cleared by STOP2 signal 0:disable/1:enable ●D7:Real position counter increase/decrease inversion function 0:disable/1:enable ●D8:Speed prior during S-curve acceleration/deceleration 0:disable/1:enable ●D15~9 Interrupt 0:disable/1:enable ●D9:Logical/real position counter>COMP-variation ●D10:Logical/real position counter<COMP-variation ●D11:Logical/real position counter<COMP+ variation ●D12:Logical/real position counter>COMP+variation ●D13:Termination of constant speed drive during acceleration/deceleration driving ●D14:Start of constant speed drive during acceleration/deceleration driving ●D15:Termination of driving
0	1	0	XWR2 YWR2	X axis mode register 2 Y axis mode register 2	Setting of enable/disable of software limit, limit input signal mode setting, driving pulse mode, encoder input signal mode and the logical levels and enable/disable of servo motor signal for each axis.  ●D1,0 Software limit 0:disable/1:enable ●D2 Hardware limit 0:instant/1:decelerating stop ●D4,3 Logical level of limit signal 0:Low/1:Hi ●D5 COMP+/- register comparison 0:logical position counter/1:real position counter ●D6 Drive pulse outputting type 0:2-pulse system /1:1-pulse 1-direction system ●D7 Logical level of drive pulse 0:positive logical pulse /1:negative logical pulse ●D8 Logical level of the direction signal 0:Low level for + direction/1:Hi for + direction ●D9 Encoder input signals 0:2-phase pulse/1:Up/Down pulse ●D11,10 Encoder input divide 00:1/1,01:1/2,10:1/4 ●D12 Logical level of ALARM signal 0:Low/1:Hi ●D13 ALARM signal 0:disable/1:enable ●D14 Logical level of INPOS signal 0:Low/1:Hi ●D15 INPOS signal 0:disable/1:enable
			BP1P		Bit pattern interpolation X-axis + direction bit data
0	1	1	XWR3 YWR3	X axis mode register 3 Y axis mode register 3	Setting of the manual deceleration, symmetry/non-symmetry of acceleration/deceleration, external operation mode, general purpose output/drive status output switcing and input signal filter.  Filter time constant Input signal filter enable/disable ●D0 Deceleration of fixed pulse drive 0:automatic/1:manual ●D1 Decelerating speed during deceleration 0:using value of accelerating speed(Symmetry)/1:using value of decelerating speed(non-symmetry) ●D2 Acceleration/deceleration mode 0:Trapezoidal/1:S-curve ●D4,3 External driving operation 00:disable/01:continuous drive/10:fixed pulse drive/11:manual pulsar ●D5 Prevention of the triangle forms at linear acceleration/deceleration driving 0:disable/1:enable ●D6 Position counter variable ring 0:disable/1:enable ●D7 nOUT7~0 Output pin selecting 0:outputting OUT7~0 /1:outputting drive status(DSND,CNST,ASND,DRIVE,CPM,CMP,ACDSND and ACASND) ●D8 EMG,LMTM/M,STOP0,1 signal filter 0:disable/1:enable ●D9 STOP2 signal filter 0:disable/1:enable ●D10 INPOS and ALARM signal filter 0:disable/1:enable ●D11 EXPP/M signal filter 0:disable/1:enable ●D12 IN5~0 signal filter 0:disable/1:enable ●D15~D13 Setting of input filter time constant(000:0.002msec/ 001:0.2msec/ 010:0.5msec/ 011:1msec/ 101:4msec/ 110:8msec/ 111:16msec)
			BP1M		Bit pattern interpolation X-axis -direction bit data.
1	0	0	WR4	Output register	Setting of general output signal nOUT7~0. 0:Low/ 1:Hi 
			BP2P		Bit pattern interpolation Y-axis +direction bit data.
1	0	1	WR5	Interpolation mode register	Setting of constant vector speed mode to execute interpolation drive, single step mode and interrupt in interpolation.  Interrupt Single step Multichip axes Constant interpolation interpolation vector speed ●D9,8 Constant vector speed 00:disable/01:2-axis constant vector speed ●D11,10 Multichip axes interpolation 00:non-execution/01:mainchip/10:subchip XY/11:subchip X ●D12 1:Single step interpolation by external signal(MPLS) ●D13 1:Single step interpolation by the command ●D14 Interrupt in continuous interpolation 0:disable/1:enable ●D15 Interrupt in bit pattern interpolation 0:disable/1:enable
			BP2M		Bit pattern interpolation Y-axis -direction bit data.
1	1	0	WR6	Write data register 1	Setting of the low word 16 bit data for data writing. (D15~D0)
1	1	1	WR7	Write data register 2	Setting of the high word 16 bit data for data writing. (D31~D16)

●The above table shows the address for 16-bit data bus. In 8-bit data bus access, using the address data for A3~A0, the 16-bit data bus are divided into the high word byte (D15~8) and the low word byte (D7~0). ●Each X and Y axis has WR1,WR2 and WR3 (mode register 1, 2 and 3). Writing the data in these registers by the same address. It depends on the axis assignment of the last command to write the data in the mode register of which axis. Or, user can select the axis by writing the NOP command which is assigned an axis just before. ●BP1~2P and BP1~2M for bit pattern interpolation can not be written just after resetting. It is resolved by operating BP register data writing enabling (36h). ●At resetting, all the bits of nWR1, nWR2, nWR3, WR4 and WR5 registers are cleared to 0(n=X and Y). The other registers are undetermined.

Read register

Address			Symbol	Register name	Contents
A2	A1	A0			
0	0	0	RR0	Main status register	Displaying drive and error status of each axis. Displaying interpolation driving status. D15 D14 D13 D12 D11 D10 D9 D8 D7 D6 D5 D4 D3 D2 D1 D0 - BPSC1 BPSC0 ZONE2 ZONE1 ZONE0 CNEXTI DRV - - Y-ERR X-ERR - - Y-DRV X-DRV error of each axis drive of each axis ●D1,0 1:driving ●D5,4 1:error occurring(become "1" whichever from RR2/D6~0, RR1/D15~12.) ●D8 1:interpolation driving ●D9 1:writable the next data of continuous interpolation ●D12~10 circular interpolation quadrant 000:0, 001:1, 010:2, ...111:7 ●D14, 13 bit pattern interpolation stack counter 00:0,01:1,10:2,11:3
0	0	1	XRR1 YRR1	X-axis status register 1 Y-axis status register 1	Displaying the comparison of position counter and COMP± register, status of acceleration/deceleration during the driving and driving termination status. D15 D14 D13 D12 D11 D10 D9 D8 D7 D6 D5 D4 D3 D2 D1 D0 [EMG ALARM LMT- LMT+ - STOP2 STOP1 STOP0 ADSND ACNST AASND DSND CNST ASND CMP- CMP+ status of driving termination ●D0 1:position counter≥COMP+ ●D1 1:position counter<COMP- ●D2 1:accelerating ●D3 1:constant speed driving ●D4 1:decelerating ●D5 1:increasing accelerating/decelerating speed ●D6 1:constant speed of accelerating/decelerating ●D7 1 decreasing accelerating/decelerating speed ●D15~8 1:factor of driving termination
0	1	0	XRR2 YRR2	X-axis status register 2 Y-axis status register 2	Displaying the error information. D15 D14 D13 D12 D11 D10 D9 D8 D7 D6 D5 D4 D3 D2 D1 D0 - - - - - - - - - - MULTI EMG ALARM HLMT- HLMT+ SLMT- SLMT+ ●D0 1:+direction software limit ●D1 1:-direction software limit ●D2 1:+direction limit signal on ●D3 1:-direction limit signal on ●D4 1:alarm signal on for servo motor ●D5 1:emergency stop signal on ●D6 1:error occurring in sub chip at multichip interpolation driving
0	1	1	XRR3 YRR3	X-axis status register 3 Y-axis status register 3	Displaying the factor of interrupt occurring (interpolation excluded). D15 D14 D13 D12 D11 D10 D9 D8 D7 D6 D5 D4 D3 D2 D1 D0 - - - - - - - - D-END C-STAC-END P≥C+ P<C+ P<C- P≥C- - 1:interrupt occurring Each bit for D7~D1 is corresponding to D15~D9 of WR1(mode register1).
1	0	0	RR4	Input register 1	Displaying the status of X-axis input signal. 0:Low 1:Hi D15 D14 D13 D12 D11 D10 D9 D8 D7 D6 D5 D4 D3 D2 D1 D0 [X-LM- X-LM+ X-IN5 X-IN4 X-IN3 X-IN2 X-IN1 X-IN0 X-ALM X-INP X-EX- X-EX+ EMG X-ST2 X-ST1 X-ST0
1	0	1	RR5	Input register 2	Displaying the status of Y-axis input signal. 0:Low 1:Hi D15 D14 D13 D12 D11 D10 D9 D8 D7 D6 D5 D4 D3 D2 D1 D0 [Y-LM- Y-LM+ Y-IN5 Y-IN4 Y-IN3 Y-IN2 Y-IN1 Y-IN0 Y-ALM Y-INP Y-EX- Y-EX+ - Y-ST2 Y-ST1 Y-ST0
1	1	0	RR6	Read data register 1	Setting of the low word 16 bit data for data reading. (D15~D0)
1	1	1	RR7	Read data register 2	Setting of the high word 16 bit data for data reading. (D31~D16)

●The above table shows the address for 16-bit data bus. In 8-bit data bus access, the 16bit data bus are divided into the high word byte (D15~8) and the low word byte(D7~0) using A3~A0 address signal. ●Each X and Y-axis has RR1,RR2 and RR3 (status register 1,2 and 3). Data can be read in these registers by the same address. It depends on the axis assignment of the last command to write the data in the mode register of which axis. Or, user can select the axis by writing the NOP command which is assigned an axis just before.

Data writing commands

Code	Setting Command	Symbol	Data range	Data length (byte)
00	Range	R	R8,000,000(multiple=1) ~ 16,000(=500)	4 bytes
01	Jerk	K	1 ~ 65,535	2
02	Acceleration	A	1 ~ 8,000	2
03	Deceleration	D	1 ~ 8,000	2
04	Initial speed	SV	1 ~ 8,000	2
05	Drive speed	V	1 ~ 8,000	2
06	Output pulse numbers	P	Output pulse numbers:0 ~ 268,435,455	4
	Interpolation finish point		Finish point:-8,388,608 ~ +8,388,607	4
07	Manual deceleration point	DP	0 ~ 268,435,455	4
08	Center point of circle	C	-8,388,608 ~ +8,388,607	4
09	Logical position counter	LP	-2,147,483,648 ~ +2,147,483,647	4
0A	Real position counter	EP	-2,147,483,648 ~ +2,147,483,647	4
0B	COMP+ register	CP	-1,073,741,824 ~ +1,073,741,823	4
0C	COMP- register	CM	-1,073,741,824 ~ +1,073,741,823	4
0D	Acceleration counter offset	AO	-32,768 ~ +32,767	2
0F	NOP(for switching)			

Data reading commands

Code	Reading Command	Symbol	Data range	Data length (byte)
10	Logical position counter	LP	-2,147,483,648~+2,147,483,647	4 bytes
11	Real position counter	EP	-2,147,483,648~+2,147,483,647	4
12	Current drive speed	CV	1 ~ 8,000	2
13	Acceleration / deceleration	CA	1 ~ 8,000	2
14	Maximum finish point reading for multichip linear interpolation	MX	0 ~ 8,388,607	4

Interpolation commands

Code	Commands
30	2-axis linear interpolation
31	
32	CW circular interpolation
33	CCW circular interpolation
34	2-axis BP interpolation
35	
36	BP register writable
37	BP register unwritable
38	BP data stack
39	BP data clear
3A	single step interpolation
3B	Deceleration enable
3C	Deceleration disable
3D	Interpolation interrupt clear
3E	Maximum finish point clear for multichip linear interpolation

*BP= bit pattern

Driving commands

Code	Commands
20	+direction fixed pulse drive
21	-direction fixed pulse drive
22	+direction continuous drive
23	-direction continuous drive
24	drive start holding
	drive start holding release
25	/termination status clear
26	decelerating stop
27	instant stop

Parameter calculation

at CLK= 16MHz

$$\text{Multiple (M)} = \frac{8,000,000}{R}$$

$$\text{Initial speed(PPS)} = SV \times M$$

$$\text{Jerk (PPS/SEC)} = \frac{62.5 \times 10^6}{K} \times M$$

$$\text{Drive speed(PPS)} = V \times M$$

$$\text{Acceleration (PPS/SEC)} = A \times 125 \times M$$

$$\text{Deceleration (PPS/SEC)} = D \times 125 \times M$$

The Specifications are subject to change without notice due to the technical development. 2011.2

Distributor



达格美 (上海) 集成电路有限公司
TAKUMI (SHANGHAI) INTEGRATED CIRCUIT CO.,LTD.

地址: 上海市浦东新区张杨路188号汤臣中心B栋801室
电话: 021-5840-8299 E-mail: dgmshtakumi-hkg.com
传真: 021-5840-1590 WEB: www.takumi-sh.com



3F,Grand Axe Bldg.,1-7-20 Uehara,Shibuya-Ku,Tokyo 151-0064,Japan
WEB SITE http://www.novaelec.co.jp/eng/index.html
EMAIL ADDRESS novaelec_info@novaelec.co.jp
TEL 81-3-5738-3666 FAX 81-3-5738-3665